



# RESOLUTION 08-2022

## OF THE VILLAGE OF ASHVILLE



www.ashvilleohio.gov

### A RESOLUTION AUTHORIZING THE VILLAGE ADMINISTRATOR AND FISCAL OFFICER TO EXECUTE AN AGREEMENTS OR PURCHASE ORDERS TO ADDRESS ISSUES IDENTIFIED BY STRAND ASSOCIATES REPORT AND TO EXECUTE OTHER CONTRACTS AS REQUIRED.

WHEREAS, a Village Administrator can execute agreements and submit purchase orders based upon the Strand Associate Report, Exhibit A, see ORC 731.141 for rules, Exhibit B and

WHEREAS, the Village of Ashville's Water Resource Recovery Facility needs repaired, renovated, and improved and

WHEREAS, Strand Associates contract authorization Resolution 11-2021 to evaluate the Water Resource Recovery Facility and

WHEREAS, the Ashville Village Council wishes to act upon the Strand Associate Report.

NOW, THEREFORE, be it resolved by the Village of Ashville Council

- 1) That the Village of Ashville Council authorizes the Village Administrator and Fiscal Officer to execute all necessary agreements to address items identified in the Strand Report.

Description	Vendor	Account	Account	Strand Est.	Vendor	Amount
RAS & WAS Actuators-1	Rawdon Myers, Inc.	Other-Capital	5702-800-590	\$77,820	\$23,260	\$23,260
RAS & WAS Actuators-1	Labor	Other-Capital	5702-800-590	\$0	\$25,000	\$25,000
Fiber Optic Replace-1	BJ Electric	Other-Capital	5702-800-590	\$25,00	\$35,000	\$35,000
RAS & WAS Pump Lights-1	BJ Electric	Other-Capital	5702-800-590	\$14,000	\$0	\$0
Headworks UPS Batteries-1	BJ Electric	Other-Capital	5702-800-590	\$500	\$350	\$350
Headworks Filtration Power-1	BJ Electric	Other-Capital	5702-800-590	\$1,300	\$0	\$0
Influent Pumps-2	Xylem	Other-Capital	5702-800-590	\$110,900	\$53,492	\$53,492
RAS & WAS Waterproof-3	TBD	Other-Capital	5702-800-590	\$99,650	\$0	\$99,650
Solids Handling Building-4	TBD	Other-Capital	5702-800-590	\$52,200	\$0	\$52,200
Replace VFD Cable	BJ Electric	Other-Capital	5702-800-590	\$0	\$50,817	\$50,817
Replace Underground to lift station	BJ Electric	Other-Capital	5702-800-590	\$0	\$11,398	\$11,398
Relabel panel	BJ Electric	Other-Capital	5702-800-590	\$0	\$175	\$175
Replace & relocate sludge press switch	BJ Electric	Other-Capital	5702-800-590	\$0	\$3,285	\$3,285
Relabel panel	BJ Electric	Other-Capital	5702-800-590	\$0	\$175	\$175
<b>Total</b>	<b>Exhibit A and C</b>			<b>\$356,395.00</b>	<b>\$202,777.00</b>	<b>\$354,627.00</b>

- 2) This resolution does not bind the Village of Ashville to a specific vendor listed but authorizes the use of the lowest and best pricing for the accomplishment of the Strand Associates Report objectives.

Therefore, this resolution will take effect upon passage.

Motion Offered by:

Seconded to the Motion Offered by:

Upon roll call on the adoption of the resolution, the vote was as follow:

Council Member Yes No Council Member Yes No Council Member Yes No Council Member Yes No Council Member Yes No Council Yes No  
 Roger L. Clark   Nelson R. Embrey   Randy S. Loveless   R. David Rainey   Matt Scholl   Steve Welsh

PASSED THIS 6<sup>th</sup> day of June 2022.

ATTEST:

\_\_\_\_\_  
 DATE: \_\_\_\_\_

April D. Grube, Clerk-Fiscal Officer

APPROVED:

\_\_\_\_\_  
 DATE: \_\_\_\_\_

Charles K. Wise, Mayor

Prepared: 05/10/2022  
 Revised Date: 06/03/2022  
 Review Date:

#### CERTIFICATE OF RECORDING OFFICER

I, the undersigned, hereby certify, that the foregoing is a true and correct copy of the resolution adopted by the Village of Ashville Council held on 6<sup>th</sup> day of June 2022, and that I am duly authorized to execute this certificate.



\_\_\_\_\_  
 (Original signature of April D. Grube) Clerk-Fiscal Officer  
 (TITLE)



Strand Associates, Inc.<sup>®</sup>  
425 W. Nationwide Boulevard, Suite 100  
Columbus, OH 43215  
(P) 614.835.0460

March 15, 2022

Mr. Franklin Christman, Village Administrator  
Village of Ashville  
200 East Station Street  
Ashville, OH 43103

Re: Report for Preliminary Engineering Services  
Water Resource Recovery Facility (WRRF) Corrective Action Plan  
Village of Ashville, Ohio

Dear Mr. Christman:

Enclosed are two copies of the final WRRF Corrective Action Plan. Strand Associates, Inc.<sup>®</sup> appreciates the opportunity to work hand in hand with the Village of Ashville to review the identified issues at the WRRF and arrive at recommendations to improve process operations. Thank you to your excellent operations staff for their support and assistance throughout this effort.

Please call me with questions.

Sincerely,

STRAND ASSOCIATES, INC.<sup>®</sup>

A handwritten signature in black ink that reads 'Jamie I. Mills'. The signature is written in a cursive style with a large initial 'J' and 'M'.

Jamie I. Mills, P.E.

Enclosure: Report

# Report for Village of Ashville, Ohio

---

## Water Resource Recovery Facility Corrective Action Plan



*James Mills*  
3/15/2022

Prepared by:

STRAND ASSOCIATES, INC.®  
425 West Nationwide Boulevard, Suite 100  
Columbus, Ohio 43215  
[www.strand.com](http://www.strand.com)

March 2022



**TABLE OF CONTENTS**

Page No.  
or Following

**WATER RESOURCE RECOVERY FACILITY CORRECTIVE ACTION PLAN**

**SECTION 1–INTRODUCTION**

1.01 Purpose and Scope .....	1
1.02 Location of WRRF .....	1
1.03 Related Reports and Drawings.....	2

**SECTION 2–EXISTING WATER RESOURCE RECOVERY FACILITY**

2.01 General WRRF Background .....	3
2.02 Review of Existing Site Drainage near Solids Handling Building .....	3
2.03 Review of Fiber-Optic Communications .....	4
2.04 Review of Influent Pumping.....	5
2.05 Review of RAS and WAS Sludge Pumping Station .....	6
2.06 Review of RAS and WAS Pumps Motor Control Center Indicator Lights .....	6
2.07 Review of RAS Valve Vault and WAS Valve Vault .....	7
2.08 Review of Headworks Building Evoqua Control Panel.....	8
2.09 Review of Headworks Building Filtration and Pressurization Unit.....	9

**SECTION 3–SUMMARY AND RECOMMENDATIONS**

3.01 Site Drainage near Solids Handling Building .....	10
3.02 Fiber-Optic Communications.....	13
3.03 Influent Pumping .....	14
3.04 RAS Valve Vault and WAS Valve Vault.....	15
3.05 RAS and WAS Pumps Indicator Lights.....	17
3.06 Headworks Building Evoqua Control Panel .....	18
3.07 Headworks Building Filtration and Pressurization Unit.....	18
3.08 WRRF Operational and Maintenance Review .....	18
3.09 OPCC and Prioritization of Alternatives .....	21

**TABLES**

2.04-1 Influent Pump Characteristics .....	5
2.05-1 RAS and WAS Pump Characteristics .....	6
2.07-1 RAS and WAS Valve Vault Actuator Characteristics .....	8
3.01-1 OPCC for Solids Handling Building Alternatives Nos.1 and 2.....	13
3.03-1 OPCC for Influent Pump Alternative Nos. 1and 2.....	15
3.04-1 OPCC for RAS and WAS Valve Vault Alternatives Nos.2 and 3.....	17
3.08-1 WRRF O&M Review .....	19
3.08-2 WRRF O&M Budget Comparison to Similar-Sized Facilities .....	20
3.09-1 OPCCs for Proposed Alternatives.....	23



**TABLE OF CONTENTS Continued**

3.09-2 Equipment Inventory Summary and Alternative Prioritization ..... 24

**FIGURES**

1.02-1 Project Location Map ..... 1  
 1.02-2 WRRF Site Map ..... 2  
 2.02-1 Stormwater Intrusion to the Sludge Cake Pad ..... 4  
 2.03-1 Fiber-Optic Cable Jacket Bubbling ..... 4  
 2.03-2 Crystalline Formations at End of Fiber-Optic Cables in Fiber-Patch  
 Panels ..... 5  
 2.07-1 WAS Valve Vault Actuator Relocation ..... 9  
 3.01-1 Existing North Stormwater Ditch ..... 10  
 3.01-2 Existing Sludge Cake Pad ..... 11  
 3.01-3 Sludge Cake Pad–Alternative No.1 ..... 11  
 3.01-4 Sludge Cake Pad–Alternative No.2 ..... 12  
 3.08-1 Village of Ashville O&M Budget ..... 20

**APPENDICES**

- APPENDIX A–VILLAGE OF ASHVILLE WRRF TOPOGRAPHIC MAP
- APPENDIX B–WARRANTY FOR EXISTING FIBER OPTIC
- APPENDIX C–KSB WARRANTY FOR EXISTING SUBMERSIBLE NONCLOG PUMPS
- APPENDIX D–XYLEM PROPOSAL FOR INFLUENT FLYGT PUMP REPLACEMENT
- APPENDIX E–DEZURIK WARRANTY FOR EXISTING RAS AND WAS ACTUATORS
- APPENDIX F–PERTERSON CONSTRUCTION COMPANY PROPOSAL FOR  
 ACTUATOR REPLACEMENT

**SECTION 1-INTRODUCTION**

**1.01 Purpose and Scope**

The Village of Ashville, Ohio (Village) owns and operates a water resource recovery facility (WRRF) that provides service to residents and businesses within the Village. The Village has experienced equipment issues and operational challenges at the WRRF shortly after construction was completed. The Corrective Action Plan was conducted to address and prioritize these challenges to improve existing operations.

This document presents an evaluation of Village-identified operational challenges that have been experienced since start-up of the WRRF and a plan to improve the identified issues along with an associated opinion of probable construction costs (OPCC) for improvements. The recommended improvements are prioritized so that the most critical items are addressed first, allowing the Village to appropriately sequence and budget for the planned improvements. Additionally, the document reviews the Villages annual operation and maintenance (O&M) budget and provides a comparison to similar-sized facilities.

**1.02 Location of WRRF**

The Village's WRRF is located at 3219 State Route 752, Ashville, Ohio. Figure 1.02-1 shows the location of the WRRF site and Figure 1.02-2 shows a map of the WRRF Site and structure names.

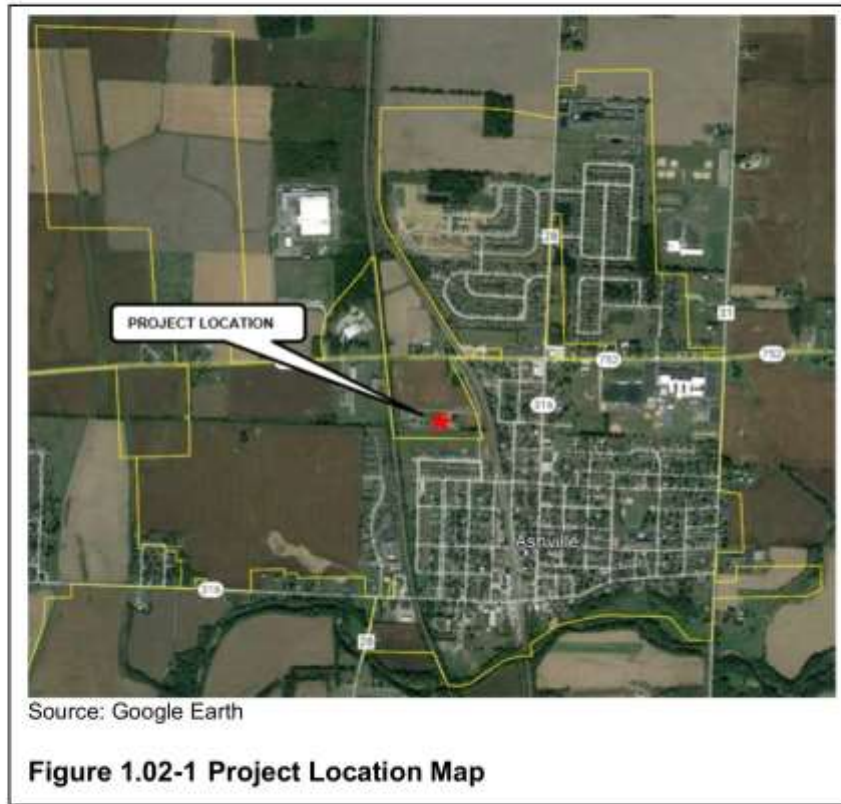



Source: Google Earth

**Structure Numbering**

- |  |  |
|--|--|
| <ul style="list-style-type: none"> <li>1–Influent Pump Station</li> <li>2–Headworks Building</li> <li>3–Oxidation Ditch Splitter Box</li> <li>4–Oxidation Ditch</li> <li>5–Oxidation Ditch Drain Vault</li> <li>6–Clarifier Splitter Box</li> <li>7–Clarifiers</li> <li>8–Ultraviolet (UV) Disinfection and Post-aeration</li> </ul> | <ul style="list-style-type: none"> <li>9–Return activated sludge (RAS) and waste activated sludge (WAS) Pump Station</li> <li>10–WAS Valve Vault</li> <li>11–RAS Valve Vault</li> <li>12–Aerobic Digesters</li> <li>13–Solids Handling Building</li> <li>14–Sludge Cake Pad</li> <li>15–Administration Building</li> </ul> |
|--|--|

**Figure 1.02-2 WRRF Site Map**

**1.03 Related Reports and Drawings**

The following reports and drawings were used in preparation of this plan.

- A. *Water Resource Recovery Facility Improvements Drawings*, prepared by URS, 2015.
- B. *Village of Ashville Water Resource Recovery Facility Topographic Map*, prepared by Tebbe Civil Engineering, 2021.
- C. *Village of Ashville Water Resource Recovery Facility Operation and Maintenance Manual (O&M Manual)*, prepared by AECOM, 2018.
- D. *Village of Ashville Water Resource Recovery Facility Project Manual (Project Manual)*, prepared by AECOM, 2015.



## SECTION 2–EXISTING WATER RESOURCE RECOVERY FACILITY

### 2.01 General WRRF Background

First put into service in 2017, the Villages new WRRF was constructed to be an improvement to the existing wastewater treatment plant (WWTP) and to allow for future planned expansions. The WRRF is rated for an average daily flow of 0.8 million gallons per day (MGD). The influent wastewater is conveyed to the influent pump station and pumped to the Headworks Building for screening and grit removal. The screened influent is then conveyed to an oxidation ditch for biological treatment. The mixed liquor flow from the oxidation ditch is split between two 55-foot-diameter clarifiers for solids settling. Clarifier effluent is conveyed to ultraviolet disinfection for pathogen inactivation before discharge to Little Walnut Creek. A portion of the settled solids located in the clarifiers is pumped back to the oxidation ditch as RAS to maintain solids suspension and the remaining solids are pumped to the aerobic digesters as WAS for solids stabilization. Following aerobic digestion, the stabilized solids are pumped to the dewatering press and stored on-site before being hauled to agricultural fields for beneficial reuse.

Since WRRF start-up, the Village staff have experienced operational issues and challenges. The Village contracted with Strand Associates, Inc.<sup>®</sup> (Strand) to prepare this corrective action plan to identify potential improvements for the following operational issues:

- Site Drainage near Solids Handling Building
- Fiber-Optic Communications
- Influent Pump Nos. 1, 2, 3
- RAS and WAS Pumps Nos. 1 and 2
- RAS and WAS Valve Vault and Valve Actuators
- RAS Pumps MCC Bucket Indicator Lights
- Headworks Building Evoqua panel power failure
- Headworks Building Pressurization and Corrosion Control Unit

### 2.02 Review of Existing Site Drainage near Solids Handling Building

The WRRF site has experienced issues with site drainage during wet weather events. The site drainage issues appear to be a result of a combination of runoff from adjacent fields, overflow from the detention pond, poor drainage characteristics of the site and no on-site storm sewer system. The most affected area is the dewatered solids storage area (Sludge Cake Pad–Structure 14 in Figure 1.02-2) of the Solids Handling Building (Structure 13 in Figure 1.02-2). The sludge cake pad receives and stores dewatered sludge from the dewatering press until it is removed from the WRRF. A 10.50-inch-wide trench drain near the periphery of the Sludge Cake Pad connects to a 4-inch drain and recycles flow to the influent pump station (Structure 1 in Figure 1.02-2).

During wet weather events, stormwater has entered the sludge cake pad and overwhelmed the trench drain, washing over the drain and rewetting the dewatered solids. WRRF staff report that stormwater has washed away the stored solids causing the rehydrated solids to enter the trench drain and then be recycled to the influent pumping station, reintroducing the solids to the treatment process. WRRF staff also report the stored dewatered solids are consistently being washed out from the Sludge Cake Pad during wet weather events. In effort to mitigate solids washout, WRRF staff have installed berms around the Sludge Cake Pad to redirect stormwater runoff away from the building and reduce stormwater entry to the Sludge Cake Pad. Figure 2.02-1 illustrates stormwater intrusion to the Sludge Cake Pad and



washing the dewatering solids to the trench drain, causing it to become inoperable. The approximate location of the trench drain is shown in red.



Figure 2.02-1 Stormwater Intrusion to the Sludge Cake Pad

### 2.03 Review of Fiber-Optic Communications

The fiber-optic cables installed throughout the WRRF are experiencing jacket bubbling, shown in Figure 2.03-1, and crystalline structures are forming at the ends of the cables, shown in Figure 2.03-2. There are concerns about the fiber-optic supervisory control and data acquisition (SCADA) system network being at risk for premature failure.

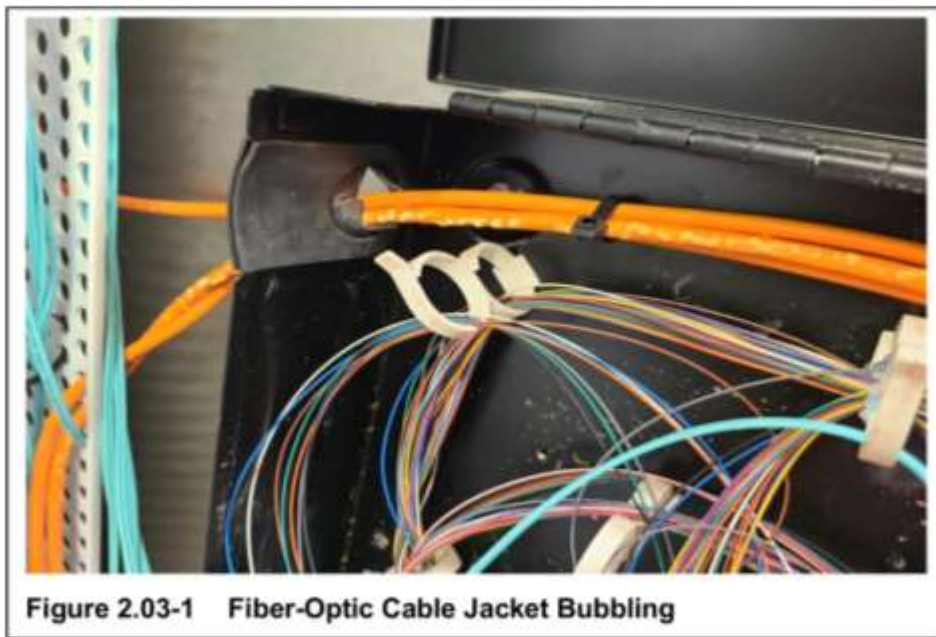
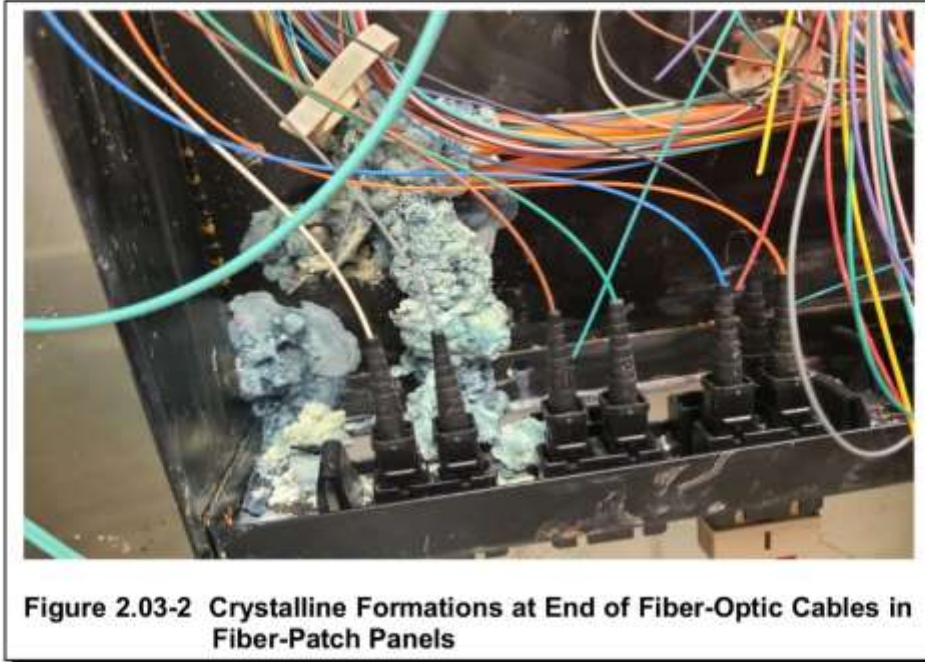

Figure 2.03-1 Fiber-Optic Cable Jacket Bubbling



**Figure 2.03-2 Crystalline Formations at End of Fiber-Optic Cables in Fiber-Patch Panels**

**2.04 Review of Influent Pumping**

Raw wastewater from the Village's service area is conveyed to the wet well of the WRRF's Influent Pump Station (Structure 1 in Figure 1.02-2). Three submersible influent pumps are located within the wet well and pump influent wastewater to the Headworks Building (Structure 2 in Figure 1.02-2) for preliminary treatment. The existing Influent Pump Station has been constructed with space to accommodate a future fourth influent pump of equivalent size. Each of the three existing influent pumps have a capacity of 913 gallons per minute at 43 feet of total dynamic head (TDH).

Table 2.04-1 represents characteristics of the WRRF influent pumps. Information for Table 2.04-1 was retrieved from the O&M Manual and Project (provided by AECOM) and confirmed on-site.

Characteristic	Value
Number of Influent Pumps	3
Influent Pump Manufacturer	KSB
Influent Pump Model	KRT K 150-315/156XG-S
Influent Pump Specified Impeller Type	Multivane (2 vanes) Enclosed Nonclog Radial Impeller
Influent Pump Starter Type	Variable Frequency Drive (VFD)
Influent Rated Capacity (each)	913 gallons per minute (gpm) at 43 feet TDH
Influent Pump Rated Speed (each)	1,167 revolutions per minutes (rpm)
Influent Pump Motor Horsepower (each)	20 horsepower (hp)
Influent Pump Electrical Characteristics	460-volt, three-phase, 60-hertz

**Table 2.04-1 Influent Pump Characteristics**

The influent pumps are designed to be non-clog pumps and the Village has experienced several clogging issues since installation. WRRF staff report the influent pumps periodically require service for cleaning and unclogging. WRRF staff report influent pump clogging is primarily due to fibrous material as well as rags and wipes building up at the impeller.

Village staff have replaced two of the existing influent KSB pumps. One influent KSB pump has been replaced with a Flygt pump Model NP-3153 and the other has been replaced with a new KSB pump of the same model. WRRF staff report preferring Flygt pumps for this application. Village staff have reported that the third original influent KSB pump has failed and is currently out of service.

**2.05 Review of RAS and WAS Sludge Pumping**

Settled sludge from clarifiers Nos. 1 and 2 (Structure 7 in Figure 1.02-2) is pumped via two submersible pumps, one RAS and one WAS pumps located at the RAS and WAS Pump Station (Structure 9 in Figure 1.02-2). These pumps convey activated sludge to the oxidation ditch (Structure 3 in Figure 1.02-2) to maintain solids suspension for biological treatment and also convey WAS to the aerobic digesters (Structure 12 in Figure 1.02-2) for solids stabilization during wasting cycles depending on the accumulated sludge depth within the clarifiers.

Table 2.05-1 represents characteristics of the WRRF RAS and WAS pumps. Information for Table 2.05-1 was retrieved from the O&M Manual and Project Manual and confirmed on-site.

Characteristic	Value
Number of RAS and WAS Pumps	2
Influent Pump Manufacturer	KSB
Influent Pump Model	KRT D 100-316/126XG-S
Influent Pump Specified Impeller Type	Open Single Vane
Influent Pump Starter Type	VFD
Influent Rated Capacity (each)	852 gpm at 41.85 feet TDH
Influent Pump Rated Speed (each)	1,160 rpm
Influent Pump Motor Horsepower (each)	15 hp
Influent Pump Electrical Characteristics	460-volt, three-phase, 60-hertz

**Table 2.05-1 RAS and WAS Pump Characteristics**

Similar to the influent pumps, the RAS and WAS pumps are designed to be nonclog pumps and Village staff have reported similar issues with clogging. WRRF staff believe the clogging issue was caused by an opening in the screening channel that allowed a small amount of raw wastewater to bypass the influent screen. This issue was corrected by filling the void spaces with a seal on both sides of the influent screen. WRRF staff report the RAS and WAS pump clogging issue has improved since sealing the void spaces in the influent channel. WRRF staff have replaced both RAS and WAS KSB pumps, one with a KSB Vortex pump and one with a Flygt pump.

**2.06 Review of RAS and WAS Pumps Motor Control Center (MCC) Indicator Lights**

During the construction of the RAS and WAS Pump Station and the installation of the RAS and WAS pump controls, a change order was executed to move each RAS and WAS pumps Hand-Off-Auto selector switch from the MCC buckets located in the electrical room of the Solids Handling Building (Structure 13



in Figure 1.02-2) to the front of the local RAS and WAS seal/motor overtemperature enclosure (Structure 9 in Figure 1.02-2). Running indicator lights for each RAS and WAS pump were also added to the front of the local RAS and WAS seal and motor overtemperature enclosure.

The wiring diagrams, Contract Documents, and As-Built documents were not updated to incorporate these changes. The new wiring added to accommodate these changes is not labeled.

When power is disconnected from RAS and WAS Pump No. 1 at the MCC bucket in the electrical room of the Solids Handling Building and RAS and WAS Pump No. 2 is running, RAS Pump No. 1 running indicator light dimly illuminates. When power is disconnected at an MCC bucket, all power should be disconnected for that equipment, including control power which is used to illuminate the indicator lights. The same situation occurs when RAS and WAS Pump No. 2 is disconnected, and RAS and WAS Pump No. 1 is running.

During on-site investigation, it was discovered that the "Running" indicator lights are illuminated when a pump is "called-to-run" instead of the "Running" indicator light illuminating when the pump is actually running (via each VFD running status output).

## 2.07 Review of RAS Valve Vault and WAS Valve Vault

The RAS and WAS Valve Vaults provide valving to control RAS and WAS flows and provide sludge flow metering. The WAS Valve Vault (Structure 10 in Figure 1.02-2) is a 4 by 5-foot structure and approximately 13 feet below surface grade. The WAS Valve Vault contains a 4-inch magnetic flow meter to measure WAS flow, a 4-inch modulating plug valve controlled by a motorized actuator to allow or isolate sludge flow to the aerobic digesters, and a sump pump that pumps groundwater that infiltrates the Valve Vault to the RAS and WAS Pump Station.

The RAS valve vault (Structure 11 in Figure 1.02-2) is a 6-foot-8-inch by 5-foot-4-inch structure and approximately 15 feet below surface grade. The RAS valve vault contains a 6-inch magnetic flow meter to measure RAS flow, two 6-inch modulating plug valves controlled by motorized actuators to direct sludge flow to either the outer ring of the oxidation ditch or to the oxidation ditch splitter box and a sump pump that pumps groundwater that infiltrates the valve vault to the oxidation ditch drain vault (Structure 5 in Figure 1.02-2).

WRRF staff report water infiltration into the RAS and WAS Valve Vaults from both surface water and a high groundwater table. Sump pumps located in the valve vaults have failed likely because of long continuous run times from the volume of water entering the vaults. WRRF staff report that issues with valve actuators include motherboard malfunctions, failing heating elements, and loss in open and close control. Because of sump pump failures, the motorized actuators have become submerged (the motorized actuators are not rated for continuous submergence) and are no longer working. The Village reports the sump pumps as well as four motorized valve actuators have required replacement within the RAS and WAS Valve Vaults.

Table 2.07-1 represents characteristics of the WRRF RAS and WAS valve vault actuators. Information for Table 2.07-1 was retrieved from the O&M Manual and Project Manual.

Characteristic	RAS Valve Vault	WAS Valve Vault
Number of Actuators	2	1
Actuator Manufacturer	AUMA	AUMA
Actuator Model	AC 01.2	AC 01.2
Actuator Enclosure	NEMA 4X/6P	NEMA 4X/6P
Actuator Size	6-inch	4-inch
Actuator Electrical Characteristics	460-volt, three-phase, 60-hertz	460-volt, three-phase, 60-hertz
Existing Condition	Submerged and not operational.	Installed aboveground and functional.

**Table 2.07-1 RAS and WAS Valve Vault Actuator Characteristics**

When WRRF staff replaced the actuator located at the WAS Valve Vault it added an extended valve stem that allowed the actuator to be installed directly above, but outside of the Valve Vault, shown in Figure 2.07-1. WRRF staff have reported good success with its clever improvement. WRRF staff reported the flow meters located within the RAS and WAS Valve Vaults are submerged and still working without issue. Furthermore, the replacement sump pump within the RAS Valve Vault has failed and the two existing actuators are submerged, these are no longer working and requires replacement.



**Figure 2.07.1 WAS Valve Vault Actuator Relocation**

**2.08 Review of Headworks Building Evoqua Control Panel**

When power to the Headworks Building Evoqua Control Panel is disconnected by shutting off the lighting panel branch breaker, the Evoqua Control Panel immediately shuts down. The Evoqua Control Panel has an uninterruptable power supply (UPS), which should provide power to the control panel when lighting panel branch circuit power is removed.



Before shutting off the lighting panel branch breaker, the UPS in the Evoqua Control Panel indicated that it had a 100 percent full battery. When the branch circuit was shut off, the UPS immediately indicated that it had 0 percent battery charge. This indicates the batteries in the UPS are no longer are capable of holding a charge.

## **2.09 Review of Headworks Building Filtration and Pressurization Unit**

The Headworks Building electrical room filtration and pressurization unit can run in "Hand" mode but will not run in "Auto" mode. The "Power Failure" indicator light was illuminated on the front of the control panel. The B-phase of the three-phase power fuses in the control panel was blown.



## SECTION 3—SUMMARY AND RECOMMENDATIONS

### 3.01 Site Drainage near Solids Handling Building

Because of the existing flat nature of the site, drainage and conveyance of stormwater can be a challenge. Upon evaluation of recent topographical data included in Appendix A, it appears the proposed grading of the site, from the 2015 Water Resource Recovery Facility Improvements (Sheet SW-4), was not performed in some areas. According to proposed plans, there was a ditch to be installed on the north side of the site. The ditch was intended to slope toward the west side of the site and convey runoff to the detention ponds. However, based upon existing site conditions, it appears the ditch was not constructed as part of the 2015 Water Resource Recovery Facility Improvements (as shown in Figure 3.01-1). These elevation discrepancies compounded with off-site runoff may be contributing to the lack of adequate site drainage.



**Figure 3.01-1 Existing North Stormwater Ditch**

The driveway elevation east of the Sludge Cake Pad entrance is at elevation 709.9, as shown in Appendix A. The northeast top slab elevation of the Sludge Cake Pad is 710.50 according to the Solids Handling Building Foundation Plan (Sheet 9S-1) of the 2015 *Water Resource Recovery Facility Improvements*. The Sludge Cake Pad floor slopes 4 inches from the northeast top slab elevation so the trench drain elevation is approximately 710.17. Thus, the driveway elevation east of the Sludge Cake Pad is approximately 3.24 inches lower than the elevation of the trench drain. Though the elevation difference suggests that stormwater runoff would not enter the sludge cake pad, visually, it appears the driveway and concrete apron slope to the trench drain (refer to in Figure 3.01-2).



To improve existing site drainage conditions, Strand proposes the following alternatives:

A. Alternative No.1

Construct a 6-inch concrete curb (speed bump) for approximately 85 linear feet (LF) to surround the perimeter of the concrete apron of the Sludge Cake Pad to limit stormwater runoff from entering the Sludge Cake Pad. Alternative No.1 is shown in Figure 3.01-3.

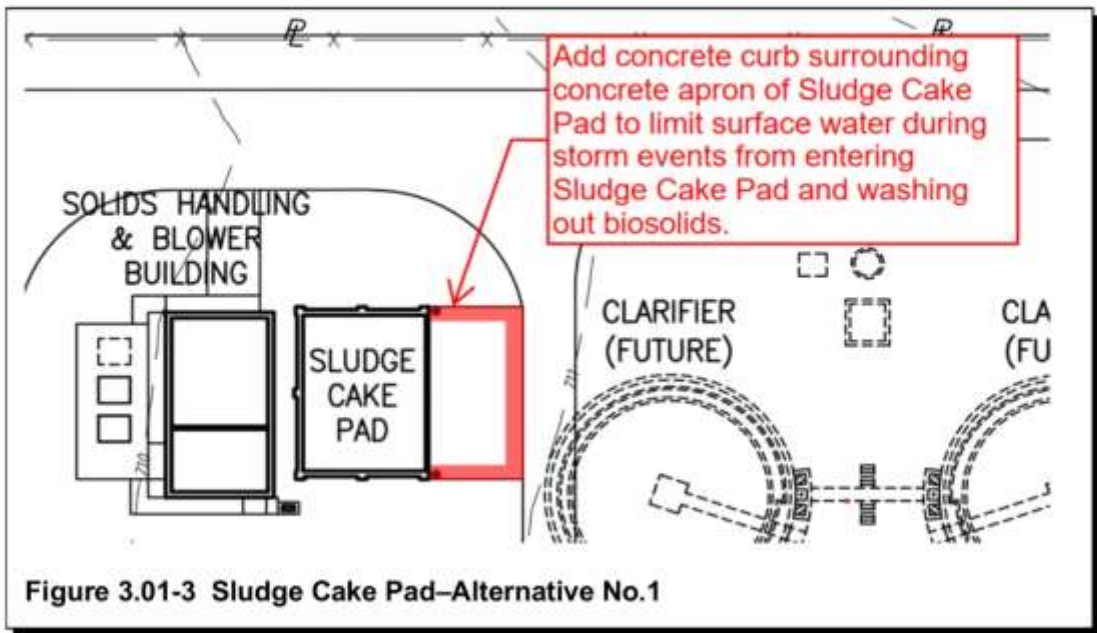



**B. Alternative No.2**

Excavate and regrade the existing ditch for approximately 400 LF to restore functionality to improve conveyance of stormwater runoff from the adjacent north field. Regrading of the ditch is anticipated to be 8 feet wide and 3 feet deep. Alternative No.2 is shown in Figure 3.01-4.

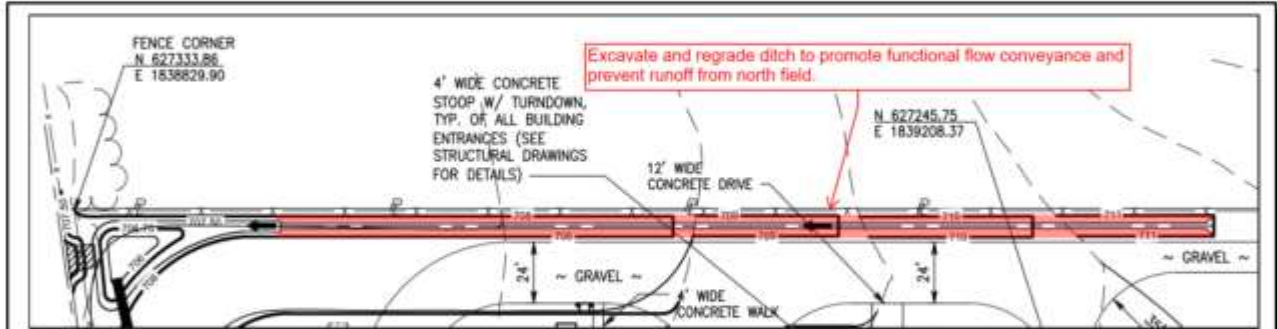

**Figure 3.01-4 Sludge Cake Pad-Alternative No.2**

Alternative No.1 reduces stormwater runoff from directly entering the Sludge Cake Pad. This is the most cost-effective alternative, as it can potentially be completed in-house by Village staff and reduces stormwater interaction with the dewatered solids. However, it does not improve site runoff issues and only minimizes stormwater washout of the dewatered solids. Additionally, from an operational perspective, the curb would be similar to a speed bump in construction and would have to be driven over continuously during sludge loadout from the Sludge Cake Pad.

Alternative No.2 redirects stormwater runoff away from the Sludge Cake Pad and to the stormwater ditch. This Alternative requires excavation and regrading of the ditch to restore its intended functionality. Alternative No.2 reduces runoff from the north agricultural field and promotes improved site drainage to the ditch. The OPCC for the alternatives are included in Table 3.01-1.



Item	Alternative No.1 Cost (Curb Addition)	Alternative No.2 Cost (Ditch Regrading)
Concrete Curb Installation (85 LF, 6-inch curb)	\$3,500	
Erosion Control	\$200	\$800
Construction Staking		\$2,000
Demolition of North Fence (400 LF)		\$3,000
Excavation for Regrading Ditch (400 LF, 8 feet wide, 3 feet deep)		\$10,000
Finish Grading		\$1,000
Install New Fence (400 LF)		\$17,000
Seeding	\$200	\$1,350
<b>Subtotal</b>	<b>\$3,900</b>	<b>\$35,150</b>
Contractors General Conditions (10 Percent)	\$390	\$3,515
<b>Subtotal</b>	<b>\$4,290</b>	<b>\$38,665</b>
Contingencies (35 Percent)	\$1,502	\$13,533
<b>Total OPCC</b>	<b>\$5,800</b>	<b>\$52,200</b>

Note: Total OPCCs are rounded to nearest whole number

**Table 3.01-1 OPCC for Solids Handling Building Alternative Nos. 1 and 2**

Furthermore, from discussion with Tebbe Civil Engineering regarding future development surrounding the WRRF, it is anticipated the agricultural field north of the WRRF that is contributing to runoff, may soon be developed. With potential development of the northern agricultural field, it is anticipated that construction of a secondary berm would be included with the development and located along the north section of the WRRF, similar to the existing berm located along the south portion of the WRRF. Construction of a future berm along the north portion of the WRRF may significantly reduce stormwater runoff from the adjacent northern field.

**3.02 Fiber-Optic Communications**

The installed fiber-optic cables throughout the WRRF are optical fiber nonconductive plenum (OFNP) cables. OFNP cables are rated for indoor use only and are meant to be installed in plenum applications. Plenums are spaces, usually above a ceiling or below a floor, that serve as an air duct for heating, ventilation, and air conditioning (HVAC) equipment. Plenum spaces experience heated or cooled air that is then distributed through the space to the room being served by the HVAC equipment (building cavity serves as a duct).

In order for a cable to be rated for a plenum space, the cable typically requires additional minerals and compounds within the jacket of the cable to self-extinguish itself and make reignition of the cable difficult. These additional minerals and compounds make the cable susceptible to swelling and forming crystals when they come into contact with water, which is currently being seen with the existing fiber-optic cables. Water can also absorb through the jacket of these cables and cause these issues without a puncture in the cable jacket. This is why OFNP cables are rated for indoor use only and should not be installed outdoors.

Strand recommends replacing all the fiber-optic cables throughout the WRRF that are installed outdoors with fiber-optic cables that are rated for outdoor applications. The existing conduit system can be reused, unless damaged conduit is discovered.

The subcontractor's installation warranty for the fiber-optic cables along with Division 26 electrical items had a one-year warranty period, starting on October 6, 2017, and expiring on October 6, 2018. The warranty for Division 26 electrical items is enclosed in Appendix B. It is unclear what fiber optic was specified and a specified plenum rated cable would not be available for exterior use.

### 3.03 Influent Pumping

The influent and RAS and WAS pump characteristics listed in Tables 2.04-1 and 2.05-1 have been site verified and the specified pumps have been installed at the Village's WRRF. The influent pump flow rate and head requirements appear to satisfy its intended purpose and design requirements of the WRRF. Additionally, the warranty for the influent pumps enclosed in Appendix C states the warranty period is for 60 months from the date of the WRRF start-up, October 6, 2017. Thus, the warranty period for the influent pumps is still in effect and expires October 6, 2022. Village staff have reported that all O&M procedures for the pumps have been followed to maintain pump longevity and efficiency.

Strand met with KSB Representatives (KSB) on December 20, 2021, to discuss the experienced issues with the pumps and potential solutions. KSB stated the clogging is primarily due to a larger wear ring and a less than optimal impeller setup. The wear ring was originally designed with set screws to adjust the ring as wear occurred. At the site, however, the ring does not set and instead raises too high leaving a large opening for solids to accumulate and create a flow obstruction. KSB stated that it has developed a new open radial multivane impeller that it believes will correct the clogging issues. However, the existing KSB pumps cannot be retrofitted to accommodate the new style of impeller and new pumps will be required. The new pumps are KRTDmax 150-403/226XEG-S IE3. KSB has stated a test pump may be able to be provided. If the test pump performs well, the new pumps and impellers will include a performance guarantee.

Village staff have expressed interest in replacing the influent KSB pumps with new Flygt pumps as they have had successful history with Flygt pumps. A proposal from Xylem for a new Flygt pump was acquired by WRRF staff on November 15, 2021. KSB has also provided a proposal to replace the two existing KSB pumps with new KRTDmax 150-403/226XEG-S IE3 pumps. Strand recommends the following potential alternatives:

1. Replace two existing KSB pumps with new KRTDmax 150-403/226XEG-S IE3 pumps.
2. Replace two existing KSB pumps with equivalent Flygt pumps.

The OPCC for the Influent pump alternatives Nos. 1 and 2 are included in Table 3.03-1. Cost for Alternative No.1 has been developed from a proposal provided by KSB. Cost for Alternative No. 2 has been developed from a proposal provided by Xylem and acquired by WRRF Staff. The proposal is included in Appendix D and brought to present-day dollars.

Items	Cost Alternative No.1 (Two New KSB Pumps)	Cost Alternative No.2 (Two New Flygt Pumps)
Manufacturer Proposal	\$39,650	\$44,500
Electrical Contractor	\$6,050	\$6,700
Pump Installation	\$11,900	\$13,400
Bypass Pumping	\$7,400	\$7,400
<b>Subtotal</b>	<b>\$65,000</b>	<b>\$72,000</b>
Contractors General Conditions (10 percent)	\$6,500	\$7,200
<b>Subtotal</b>	<b>\$71,500</b>	<b>\$79,200</b>
Contingencies (40 percent)	\$28,600	\$31,700
<b>Total OPCC</b>	<b>\$100,100</b>	<b>\$110,900</b>

Note: Total OPCCs are rounded to nearest whole number

**Table 3.03-1 Influent Pump Alternative Nos. 1 and 2**

**3.04 RAS Valve Vault and WAS Valve Vault**

Submergence of the actuators within the RAS and WAS Valve Vaults has been a constant challenge for the WRRF staff. The existing actuators have a NEMA 4X/6P rating, thus, the enclosures are designed to withstand periods of submergence without issues. However, the actuators are not designed for continuous submergence. The high-water table of the site, surface runoff and issues with the sump pumps failing appear to be contributing to water accumulation within the valve vaults causing the actuators to be submerged longer than recommended and exceeding the National Electrical Manufacturers Associations (NEMA) rating of the actuators. The valve actuators have a one-year warranty, which is enclosed in Appendix E. The warranty period started on October 6, 2017 and expired on October 6, 2018.

Review of the project manual and drawings provided by AECOM, Specification Section 33 0517.3.1-C, states "prior to backfilling, all cracks and voids in precast concrete vaults shall be filled with non-shrink grout or polyurethane sealant, or both. Around pipe and conduit penetrations, openings shall be sealed with polyurethane sealant. With the authorization of the Engineer, grout or a closed-cell flexible insulation may be used as filler material prior to placing a final bed of polyurethane sealant." Drawings illustrate that polyvinyl chloride (PVC) water stops are typically installed within the keyway of precast concrete structures. It appears the precast concrete valve vault structures were intended to be sealed to prevent water intrusion. However, because of past challenges that WRRF staff have experienced with water intrusion at the influent wetwell from improper sealing, it is anticipated the RAS and WAS Valve Vaults may have similar issues.

WRRF staff have replaced the WAS Valve Vault actuator and added an extended valve stem and relocated it as a surface installation as shown in Figure 2.07-1. Staff have reported good success with the improved location of the actuator for the WAS Valve Vault. This application corrects the issue with continuous submergence of the actuator. However, the improvement does not correct the challenge with water entering the Valve Vaults. Strand recommends to first identify the location of water entry to the



valve vaults by pumping out the standing water in the vaults and searching for water weeping into the vaults. Two potential alternatives to mitigate further water entry to the Valve Vaults is to waterproof the exterior of the vaults or seal the precast concrete joints at the interior of the vaults. Waterproofing the Vaults exterior is likely the most effective means to mitigate further groundwater entry but will require fairly deep excavation and potentially sheeting and dewatering with the high groundwater table. Injecting a polyurethane seal within the interior of the precast concrete joints of the vaults can be effective but would not be expected to be as effective because of the continued negative pressure from water entering through the Vault's exterior. Evaluating and potentially replacing the seals for the pipe penetrations within the vaults is common to both alternatives as well as replacing the nonfunctional sump pumps.

Strand's first recommendation would be to replace the two nonfunctional actuators at the RAS Valve Vault and retrofit them as a surface installation similar to the aboveground actuator installation at the WAS Valve Vault. Strand's second recommendation would be to identify water entry locations to the RAS and WAS Valve Vaults through investigating the interior of the vaults for water entry. Once water entry locations are identified, the vaults may potentially be able to be sealed from the interior or the exterior of the vaults waterproofed to limit further water intrusion and protect the sump pumps, plug valves, and flow meters from prolonged submergence. These two recommendations should improve equipment life expectancy for the actuators, sump pumps, flow meter, and plug valve, as well as operability of the structure, staff safety, and preventative maintenance.

The OPCC to relocate the two motor actuators located in the RAS Valve Vault and to seal the RAS and WAS Vault Vaults are detailed in Table 3.04-1. Costs to relocate the two RAS actuators were developed from a proposal acquired by WRRF staff from Peterson Construction. The proposal is included in Appendix F and has been brought to present-day dollars. The cost opinion to seal the interior of the Valve Vaults and waterproof the exterior of the Valve Vaults (Alternatives Nos. 2 and 3, respectively) are preliminary and based off recent projects and bid histories.

Items	Cost Alternative No.1 (Relocate two RAS Actuators)	Cost Alternative No.2 (Seal Interior of RAS and WAS Valve Vaults)	Cost Alternative No.3 (Waterproof Exterior of RAS and WAS Valve Vaults)
Actuator Proposal	\$52,400		
Excavation around Vaults			\$16,000
Sheeting around Vaults			\$15,000
Dewatering			\$10,000
Water Proofing Exterior of Vaults			\$6,100
Backfill			\$10,000
Finish Grading			\$1,000
Seeding			\$2,000
Seal Interior of Vaults		\$20,000	
Replace Seals for Vault Pipe Penetrations		\$4,500	\$4,500
Replace Sump Pump		\$2,500	\$2,500
<b>Subtotal</b>	<b>\$52,400</b>	<b>\$27,000</b>	<b>\$67,100</b>
Contractors General Conditions (10 Percent)	\$5,240	\$2,700	\$6,710
<b>Subtotal</b>	<b>\$57,640</b>	<b>\$29,700</b>	<b>\$73,810</b>
Contingencies (35 Percent)	\$20,180	\$10,400	\$25,834
<b>Total OPCC</b>	<b>\$77,820</b>	<b>\$40,100</b>	<b>\$99,650</b>

\*Total OPCCs are rounded to nearest whole number

**Table 3.04-1 RAS and WAS Valve Vault Alternative Nos. 1, 2, and 3**

**3.05 RAS and WAS Pumps Indicator Lights**

Strand recommends the control wiring associated with the change order modifications to the local RAS and WAS seal and motor overtemperature enclosure (Hand-Off-Auto selector switch and running indicator light addition) for each RAS and WAS pump be reconfigured. The existing control wiring is recommended to be tested, traced out, labeled, and properly documented. The existing wiring can be reused if confirmed to be in good shape, and any wires which are damaged will need to be replaced. If any wires are discovered to have been damaged, the associated conduit system is recommended to be investigated to determine whether damaged or broken conduits are the cause of the damaged wiring.

The running indicator lights on each RAS and WAS MCC bucket in the electrical room of the Solids Handling Building and the running indicator lights at the local RAS and WAS seal and motor overtemperature enclosure are recommended to be wired to the associated VFD in each MCC bucket such that the running indicator lights are illuminated when the VFD provides a "Running" status output. If the existing wiring is confirmed to be in good shape, this change would likely only require modifications of the running indicator light circuit wiring in each MCC bucket and at the local RAS and WAS seal and motor overtemperature enclosure.

It has been confirmed via on-site investigation that the SCADA system is receiving each RAS and WAS pump "Running" status from the associated RAS and WAS Pump VFD. Therefore, no modifications to the SCADA system RAS and WAS pump running status will be required.

It was also discovered that the local RAS and WAS pump disconnects at the RAS and WAS Pumping Station have auxiliary contacts that are currently not used. These auxiliary contacts would allow maintenance staff to deenergize the associated RAS and WAS pump control circuit to the RAS and WAS Pumping Station seal and motor overtemperature enclosure and the associated RAS and WAS Pump MCC bucket in the electrical room of the Solids Handling Building via the local RAS and WAS pump disconnect. Strand recommends using these local disconnect auxiliary contacts to fully deenergize the RAS and WAS pump system for the safety of the maintenance staff. Strand recommends adding wiring in existing conduit from the local RAS and WAS pump disconnects auxiliary contacts to the associated RAS and WAS pump MCC buckets.

### **3.06 Headworks Building Evoqua Control Panel**

Strand recommends replacing the UPS batteries in the Evoqua Control Panel. The existing UPS batteries appear to no longer hold a charge.

### **3.07 Headworks Building Filtration and Pressurization Unit**

Strand recommends replacing the B-phase power fuse in the unit control panel. The Altivar ATV312 VFD appears to be programmed to ignore single-phase power failure when operating in "Hand" mode but does not ignore single-phase power failure when operating in "Auto" mode.

In addition, it is recommended to investigate what caused the B-phase power fuse to blow and repair any discovered issues. Strand recommends modifying the VFD settings such that a single-phase power failure causes the unit to shut down in both the "Hand" or "Auto" modes.

### **3.08 WRRF Operational and Maintenance Review**

WRRF staff has stated that manufacturer recommended routine operation and maintenance (O&M) schedules for reviewed equipment have been followed. Thus, Strand believes that since equipment maintenance schedules have been routinely performed, that a lack of equipment upkeep and preventative maintenance has not played a major role in the experienced issues at the WRRF. Strand recommends that WRRF staff continue following manufacturer guidelines and recommended maintenance schedules for equipment upkeep and preventative maintenance. Table 3.08-1 shows manufacturer recommended maintenance procedures and WRRF staff actions for equipment maintenance and upkeep.



Item Description	Manufacturer Recommended O&M	WRRF Staff Actions
Influent Pumps, RAS and WAS Pumps	<p><b>Maintenance Schedule:</b></p> <ul style="list-style-type: none"> <li>• Performed every 4,000 operating hours                             <ul style="list-style-type: none"> <li>• Measure the insulation resistance</li> <li>• Check the power cables</li> <li>• Visually inspect the lifting chain and rope</li> </ul> </li> <li>• Performed every 10,000 operating hours                             <ul style="list-style-type: none"> <li>• Check the sensors</li> <li>• Check the mechanical seal leakage</li> <li>• Change the lubricant</li> <li>• Lubricate the bearings</li> </ul> </li> <li>• Performed every five years                             <ul style="list-style-type: none"> <li>• Perform a general overhaul</li> </ul> </li> </ul>	<p>Staff have reported following all Manufacturer Recommended O&amp;M procedures for pump maintenance and longevity. When pump issues developed, manufacturer representatives were contacted for review.</p>
RAS and WAS Actuators	<p><b>Maintenance Schedule:</b></p> <ul style="list-style-type: none"> <li>• Lubrication schedule is changing grease every four to six years for insulating duty and exchanging the seals when changing the grease.</li> </ul> <p><b>Preventative Maintenance:</b></p> <ul style="list-style-type: none"> <li>• Performed six months after commissioning and then the following maintenance below performed annually                             <ul style="list-style-type: none"> <li>• Visual Inspection</li> <li>• Checking tightness and seal of cable entries</li> <li>• Checking fastening screws between actuator and gearbox and valve for tightness</li> <li>• Lubricate valve stem</li> </ul> </li> </ul>	<p>Staff have reported following all Manufacturer Recommended O&amp;M procedures.</p> <p>Staff has purchased actuator faceplates to further protect the actuator screen and controls.</p>
Biosolids Management	NA	<p>Staff have developed soil berms to control erosion and direct surface runoff from the Solids Handling Building Sludge Cake Pad.</p>
Fiber Optic Communications RAS AND WAS Pump Indicator Lights Headworks Building Enroqua Control Panel Headworks Building Filtration and Pressurization Unit	NA	<p>Staff have reported when issues developed, manufacturer representatives were contacted for review.</p>

Table 3.05-1 WRRF O&M Review

The Villages existing WRRF O&M budget has been reviewed and compared to similar sized facilities, shown in Table 3.08-2.

Entity	Average Daily Flow (ADF)	Approximate Population	Median Household Income (MHI)	Number of Staff	O&M Budget
Village of Ashville	0.80 MGD	4,529	\$76,970	2	\$317,563
Village of Commercial Point	0.43 MGD	3,078	\$86,058	4	\$355,920 (2019 Sewer Operating Budget)*
City of Canal Winchester	2.48 MGD	9,107	\$95,647	4	\$498,142 (2019 Sewer Plant Budget)*
City of Wellston	1.44 MGD	5,412	\$39,318	3	\$221,000

\*Budgets were obtained through the Ohio Office of Budget and Management.  
 Population and MHI were obtained through United States Census Bureau.  
 ADF was obtained through Ohio Environmental Protection Agency National Pollution Discharge Elimination System.

**Table 3.08-2 WRRF O&M Budget Comparison to Similar-Sized Facilities**

Because of differences between labor categories, facility processes and sizes, and fine details between municipalities shown in Table 3.08-2; Strand is focusing on the Village's O&M budget in more detail with a breakdown shown in Figure 3.08-1.

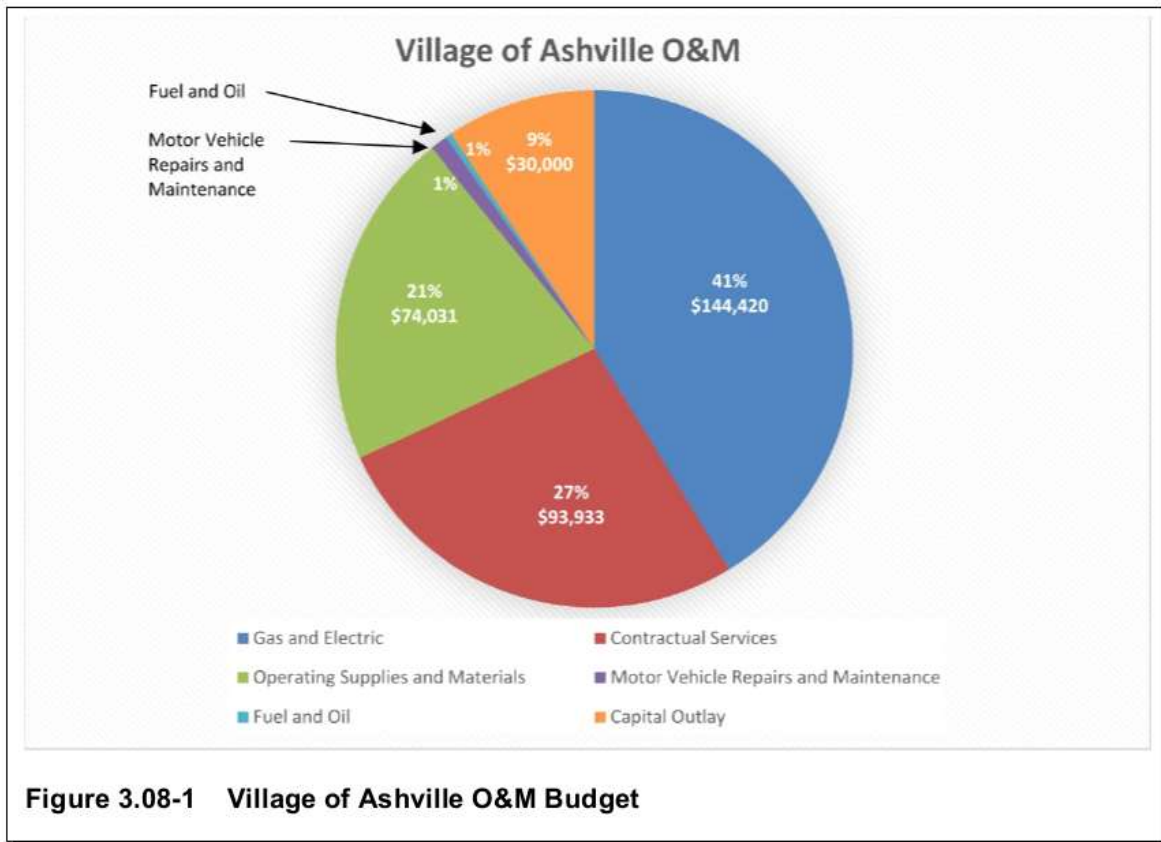

**Figure 3.08-1 Village of Ashville O&M Budget**



One noticeable criterion between facilities is the amount of staffing. The Village has two full-time WRRF staff, and responsibilities include oversight and maintaining operation of the WRRF and sanitary sewer collection system. WRRF staff also provide help with the water supply system, including water treatment, the distribution system, and meter reading. Furthermore, WRRF staff are on-call for utility emergencies and basement backups throughout the Village. WRRF operating hours are Monday through Friday from 8 A.M. to 4 P.M., equating to 40 hours per week. The WRRF manager is required to be on-site at the WRRF for 20 hours per week, and 5 hours per week reviewing the sanitary sewer collection system. Thus, the WRRF manager only has 15 hours per week for other responsibilities.

Because of limited time to address issues identified in this report and unplanned maintenance for equipment repairs and replacement (which appears to be occurring more frequently than expected) WRRF staff have had to rely significantly on contractors and manufacturers for equipment repairs rather than being able to address these items in-house. Outsourcing unplanned equipment repairs, maintenance, and replacement has exhausted the Villages Operating Supplies and Maintenance Budget and the Contractual Services Budget in previous years, leaving little budget for planned improvements.

Addressing the issues identified in this report is anticipated to reduce further unplanned equipment maintenance and repairs and reduce spending from the Villages Operating Supplies and Maintenance Budget and the Contractual Services Budget. Furthermore, hiring an additional WRRF staff member with a background in equipment maintenance could allow the Village to complete more in-house equipment repairs, which would be anticipated to offset costs for outsourcing these efforts.

The Village is anticipating significant growth in the near future with residential housing developments and commercial warehouses that may contribute an additional 500,000 gallons per day of sanitary flows to the sanitary sewer collection system and WRRF. The anticipated growth will require additional infrastructure for the sanitary sewer collection system and may require expansion of the WRRF. Thus, the scale of staff responsibility and oversight is anticipated to likely increase in response to the anticipated growth, generating a potential need to increase staffing at the WRRF.

### **3.09 OPCC and Prioritization of Alternatives**

A summary of the OPCCs for the proposed alternatives are included in Table 3.09-1 and a summary and prioritization of recommended alternatives are detailed in Table 3.09-2. The cost opinions are based on manufacturer quotations, previous proposals that have been acquired by WRRF staff, bid histories, and other historical data. The cost opinions have potential to vary because of market volatility and contractor availability.

Strand recommends the Village prioritize addressing the fiber optic communications, RAS pump indicator lights, and the Evoqua control panel and filtration and pressurization unit located in the Headworks Building first. These items are associated with controls and longevity of other equipment and pose potential safety concerns. Furthermore, the longevity of the fiber-optic cables is unknown and the consequences for losing fiber-optic communications can be significant. Thus, replacing the fiber-optic cables is anticipated to be the most critical item to prioritize.

Another initial priority recommendation is to address the two motor actuated valves located in the RAS Valve Vault. These actuators are submerged and are no longer functional. Strand's recommendation is to replace the actuators and install them at the surface of the vault to remove them from wet conditions within the vault.



**Village of Ashville, Ohio**

**Water Resource Recovery Facility Corrective Action Plan**

The second priority recommendation is to address the influent pumping issues. Strand's understanding is the Village has replaced two influent pumps, one pump with a KSB pump and the other with a Flygt pump. A third influent pump is currently out of service. Loss of influent pumping can be significant in emergency bypass pumping costs. Because of the Village's past success with using Flygt pumps, our recommendation is to replace the remaining two KSB pumps with Flygt pumps.

The third recommendation is to pump the water out of the RAS and WAS Valve Vaults to identify the water entry locations. Once the locations are identified, it is recommended to seal the interior or waterproof the exterior of the RAS and WAS Valve Vaults to limit further water infiltration to protect the existing plug valves and flow meters.

The fourth priority recommendation is to address site drainage near the Solids Handling Building. This is a maintenance item and does require additional WRRF staff oversight and maintenance but is recommended to be addressed after the more critical prioritized items are addressed first.

LL

R:\COO\Documents\Reports\Archive\2022\Ashville, Village of (OH)\WWTP Corrective Action Plan.4745.001.Feb.JIM\Report\Report.docx

Village of Ashville, Ohio

Water Resource Recovery Facility Corrective Action Plan

Item	OPCC of All Alternatives	OPCC for Recommended Alternative	Prioritization Ranking*	Items Included in Phase 1	Items Included in Phase 2	Items Included in Phase 3
<b>Solids Handling Building</b>						
Alternative No. 1-Curb Addition	\$5,800					
Alternative No. 2-Regrade Ditch	\$52,200	\$52,200	4	\$52,200		
<b>Influent Pumps</b>						
Alternative No. 1-New KSB Influent Pumps	\$100,100					
Alternative No. 3-New Flygt Pumps	\$110,900	\$110,900	2	\$110,900		
<b>RAS and WAS Valve Vaults</b>						
Alternative No. 1-Relocate RAS Actuators	\$77,820	\$77,820	1	\$77,820		
Alternative No. 2-Seal Interior Concrete Joints of the RAS and WAS Valve Vaults	\$40,100					
Alternative No. 3-Waterproof the Exterior of the RAS and WAS Valve Vaults	\$99,650	\$99,650	3	\$99,650		
<b>Fiber Optic Communications</b>						
Replace Fiber-Optic Cables	\$25,000	\$25,000	1	\$25,000		
<b>RAS AND WAS Pump Indicator Lights</b>						
Modify RAS and WAS Pump Control Wiring	\$4,000	\$4,000	1	\$4,000		
Route New Shielded Power Cable to One RAS Pump in Existing Conduit	\$10,000	\$10,000	1	\$10,000		
<b>Headworks Building Evoqua Control Panel</b>						
New UPS Batteries (owner install)	\$500	\$500	1	\$500		
<b>Headworks Building Filtration/Pressurization Unit</b>						
Investigate Power Failure and Correct Issue	\$1,300	\$1,300	1	\$1,300		
<b>Total OPCCs</b>				<b>\$381,370</b>	<b>\$0</b>	<b>\$0</b>

\*Prioritization Ranking: 1 = Most Critical Element, 4 = Least Critical Element

Table 3.09-1 OPCCs for Proposed Alternatives

Experienced Issue	Affected Criteria	Criteria Warranty	Criteria Status	Criteria Anticipated Service Life Expectancy	Alternative OPCC			Recommended Alternative	Prioritization Ranking*
					Alternative No.1	Alternative No.2	Alternative No.3		
Site drainage is occurring near Biosolids Handling Building	Biosolids	NA	Sludge Cake Pad floods during storm events	NA	Alternative No.1 Addition of Curb: \$5,800	Alternative No.2 Regrade North Ditch: \$52,200	Alternative No.2	4	
Cable jacket bubbling and developing crystalline structures on fiber optic cables	Fiber-Optic Wiring	Subcontractors warranty for Division 26 electrical items started on October 6, 2017 and expired on October 6, 2018.	NA	NA	\$25,000		NA	1	
Running Indicator lights are falsely illuminating  One RAS pump does not have shielded power cable	RAS AND WAS Pump Indicator Lights	Subcontractors warranty for Division 26 electrical items started on October 6, 2017 and expired on October 6, 2018.	NA	NA	\$4,000 for RAS and WAS Pump Indicator Lights  \$10,000 for routing new shielded power cable to one RAS pump in existing conduit.		NA	1	
Uninterruptible power supply to Headworks Building Evoqua Control Panel is not providing power upon power disconnection	Headworks Building Evoqua Control Panel	Subcontractors warranty for Division 26 electrical items started on October 6, 2017 and expired on October 6, 2018.	NA	NA	\$500		NA	1	
Headworks Building electrical room filtration and pressurization unit can run in "Hand" mode but will not run in "Auto" mode	Headworks Building Filtration and Pressurization Unit	Subcontractors warranty for Division 26 electrical items started on October 6, 2017 and expired on October 6, 2018.	NA	NA	\$1,300		NA	1	
RAS and WAS Valve Vault flooding	Plug Valve Motor Actuators	Installers warranty for elastomeric joint sealant is two years from October 6, 2017. Installers Warranty expired on October 6, 2019.  Manufacturer's warranty for elastomeric joint sealants is 20 years from October 6, 2017. Manufacturer's warranty expires on October 6, 2037.	Standing water in RAS and WAS Valve Vaults	Precast concrete structures are anticipated to have design life expectancy of 50 years  Joint Sealants are anticipated to have a design life expectancy of 20 years	Alternative No.1: Relocate two RAS motor Actuators: \$77,620	Alternative No.2: Sealing the interior Precast Concrete Joints of the RAS and WAS Valve Vault: \$40,100	Alternative No.3: Waterproofing the exterior of the RAS and WAS Valve Vault: \$89,850	Address Alternative No.1 first and then identify water entry locations to the Vaults and determine best path forward for sealing the Vaults.	1 for Alternative No.1  3 for Alternatives Nos.3 and 4
Influent Pump Functionality	Influent Pumps	Expires October 6, 2022	Pumps are clogging. Two Influent Pump have been replaced. One Influent Pump currently not functional.	Submersible pumps are anticipated to a design life expectancy of 15 to 20 years.	Alternative No.1 Replace Existing Influent Pumps with New KSB Pumps: \$100,100	Alternative No.2 Replace Existing Influent Pumps with New Flygt Pumps: \$110,900	Alternative No.2	2	

\*Prioritization Ranking: 1 = Most Critical Element, 4 = Least Critical Element

Table 3.09-2 Equipment Inventory Summary and Alternative Prioritization

## APPENDIX A VILLAGE OF ASHVILLE WRRF TOPOGRAPHIC SURVEY





**APPENDIX B  
WARRANTY FOR EXISTING FIBER OPTIC**



18817 S. R. 501 N., Box 2058, Wapakoneta, OH 45885-0558  
Phone: (419) 941-2233 Fax: (419) 941-2244  
www.petersonconstructionco.com

PROJECT NAME:	VILLAGE OF ASHVILLE, OHIO WATER RESOURCE RECOVERY FACILITY IMPROVEMENTS 3219 STATE ROUTE 752 ASHVILLE, OHIO 43103
SPEC. SECTION:	260505
PRODUCT NAME:	BASIC ELECTRICAL REQUIREMENTS
SUBCONTRACTOR:	AMELCON, LLC 1310 ESSEX AVE. COLUMBUS, OHIO 43201 614/297-6393

**Subcontractors Guarantee**

Date: October 6, 2017

Project: Village of Ashville Ohio  
Wastewater Treatment Plant

Location: 3219 State Route 752, Ashville, Ohio 43103

Owner: Village of Ashville Ohio

The undersigned, Subcontractor for Division 26 and related drawings per the subcontract agreement work on the above project, hereby guarantees all the workmanship and or materials installed by them for the period of one calendar year from the date above.

All warranty and guarantee work shall be done on a scheduled basis during normal working hours, unless determined to be an emergency by both parties. The owner shall call either 614-297-6393 or 614-679-2096 to schedule such work.

This warranty and guarantee shall not cover misuse, abuse, neglect or Acts of God.

AMELCON LLC

By: *Jon Wilkin*

Title: member

Jon Wilkin, member

cc: file

**AMELCON LLC**

1310 Essex Ave., Columbus, Ohio 43201 Mailing Address: 1059 Sailing Ct., Westerville, Ohio 43082  
614-297-6393 Fax 614-297-0328 Email Address: [amelconllc@aboglobal.net](mailto:amelconllc@aboglobal.net)  
Ohio License 16177 28168

# APPENDIX C KSB WARRANTY FOR EXISTING SUBMERSIBLE NONCLOG PUMPS



18817 S. R. 501 N., Box 2058, Wapakoneta, OH 45895-0568  
Phone: (419) 941-2233 Fax: (419) 941-2244  
www.petersonconstructionco.com

PROJECT NAME:	<b>VILLAGE OF ASHVILLE, OHIO WATER RESOURCE RECOVERY FACILITY IMPROVEMENTS</b> 3219 STATE ROUTE 752 ASHVILLE, OHIO 43103
SPEC. SECTION:	432139.13
PRODUCT NAME:	SUBMERSIBLE NON-CLOG PUMPS
SUBCONTRACTOR:	TED BAKER & ASSOCIATES 1284 SOM CENTER ROAD, SUITE 215 CLEVELAND, OHIO 44124 614/361-3673



Pumps and Mixers

Warranty for Municipal and Industrial Installations

## 24/60 Month Warranty For Pumps And Mixers - Ashville WRRF KSB O#85512 (Pro-rated)

KSB, Inc. warrants to the Original End Purchaser that its Pump(s) will be free from defects in workmanship and materials covering parts and labor for a period of sixty (60) months of operation when pumping abrasive-free, non-corrosive liquids used in Municipal and Industrial Installations. This warranty period will in no way exceed sixty (60) months from date of plant start up, October 6, 2017.

In the event that defects in workmanship or materials appear during the term of the warranty, the Purchaser shall deliver written claim of Warranty to the Company within ninety (90) days of discovery. The obligation of KSB, Inc. under the warranty shall be limited to replacement of defective part(s) and/or labor whichever KSB, Inc., in its sole discretion, chooses to elect. The Original End Purchaser shall be entitled to this warranty provided that the terms of payment have been complied with and the pump(s) with cable(s) attached or faulty part(s) thereof have been returned freight prepaid to KSB, Inc. or to an authorized KSB-Service facility and the defect has been acknowledged in writing by KSB, Inc. to be caused by faulty workmanship or defective material. Normal wear and tear is specifically excluded from warranty coverage.

The warranty shall be void if the pump(s) or its part(s) have not been used and maintained in accordance with the printed instructions of KSB, Inc., or have been damaged wholly or in part by misuse, accident, neglect, faulty electrical system, or any other cause beyond the control of KSB, Inc.

Unless otherwise specified by KSB, Inc., the warranty period shall be computed from the original shipping date to the date the pump(s) and/or part(s) are returned to KSB, Inc. or, if repairs are made on site, the warranty period shall be computed to the date notice of defects is received by KSB, Inc.

Pump(s) or part(s) repaired or replaced will be returned at the cost of the Original End Purchaser. Repairs or replacement parts are warranted free from defects in workmanship and materials for the longer of the un-expired term of this warranty or ninety (90) days from the date KSB, Inc. ships such repaired or replaced items, and all other terms and conditions of this warranty shall apply.

Electrical system schematics (including bills of material) may be required to support any warranty claims at the request of KSB, Inc. This documentation will normally be required in the case of pumps or 20 horsepower and larger.

**KSB, INC. WILL NOT BE RESPONSIBLE FOR TRAVEL EXPENSES, RENTED EQUIPMENT, OUTSIDE CONTRACTORS' FEES, UNAUTHORIZED REPAIR, SHOP EXPENSES OR FOR PUMPS PURCHASED OR USED WITHOUT KSB SUPPLIED POWER CABLE(S).**

**THE WARRANTIES MADE HEREIN BY KSB, INC. ARE IN LIEU OF ANY AND ALL OTHER WARRANTIES, EXPRESSED OR IMPLIED. KSB, INC. DISCLAIMS ANY AND ALL WARRANTIES FOR MERCHANTABILITY OR FITNESS FOR A PARTICULAR PURPOSE. KSB, INC. ASSUMES NO LIABILITY FOR LOSS OF USE, LOSS OF PROFIT, OR ANY DIRECT, INDIRECT, INCIDENTAL, OR CONSEQUENTIAL DAMAGES OF ANY KIND.**

No sales agent or sales representative or any other person is authorized to modify, extend, or enlarge this Warranty. Any modification, extension, or enlargement of this Warranty shall not bind KSB, Inc.

100% two (2) years after October 6, 2017  
50% next three (3) years. (Years 3-5)

Revised 3/2010

Supersedes all previously published warranties

**APPENDIX D**

**XYLEM PROPOSAL FOR INFLUENT FLYGT PUMP REPLACEMENT**



*Xylem Water Solutions USA, Inc.  
Flygt Products*

November 15, 2021

1615 State Route 131  
Milford, Ohio 45150  
Tel 513/831-7867  
Fax 513/831-7868

VLG OF ASHVILLE  
PO BOX 195  
ASHVILLE OH 43103-0195

Quote # 2021-CIN-0816  
Project Name: Flygt 3153 Influent Pump 1. 11-15-21  
Job Name:

Xylem Water Solutions USA, Inc. is pleased to provide a quote for the following Flygt equipment.

Influent Pump 1				
Qty	Part Number	Description	Unit Price	Extended Price
1	3153.185-0918	Flygt Model NP-3153.185 6" volute Submersible pump equipped with a 460 Volt / 3 phase / 60 Hz 15 HP 1750 RPM motor, 435 impeller, 1 x 50 Ft. length of SUBCAB 4G10+S(2x0.5) submersible cable, FLS leakage detector, volute is prepared for Flush Valve	\$ 15,032.25	\$ 15,032.25
1	14-69 00 09	START UP CHARGE FLYGT 1-TP MODELS: 3000,7000,8000	\$ 1,496.00	\$ 1,496.00
1	602 33 06	CONNECTION,DISCH 5 1/2X6" CI	\$ 1,197.00	\$ 1,197.00
1	14-58 95 35	HARDWARE,DISC CONN ASSY 304SS	\$ 346.50	\$ 346.50
1	14-40 71 29	MINI-CASII/FUS 120/24VAC,24VDC	\$ 472.50	\$ 472.50
1	14-40 70 97	SOCKET,11 PIN OCTAL DIN MOUNT	\$ 46.50	\$ 46.50
1	613 68 04	BRACKET,GUIDE BAR UPPER 2" 316	\$ 193.50	\$ 193.50
2	14-58 42 52	BRACKET,INT GB 2 X 8" 316SS+ FOR CVD PIPE	\$ 340.50	\$ 681.00
<b>Total Price</b>				<b>\$ 19,465.25</b>
<b>Freight Charge</b>				<b>\$ 1,115.00</b>
<b>Total Price</b>				<b>\$ 20,580.25</b>

**Terms & Conditions**

This order is subject to the Standard Terms and Conditions of Sale – Xylem Americas effective on the date the order is accepted which terms are available at <http://www.xylem.com/en-us/Pages/terms-conditions-of-sale.aspx> and incorporated herein by reference and made a part of the agreement between the parties.

**Purchase Orders:** Please make purchase orders out to: Xylem Water Solutions USA, Inc.

**Freight Terms:** 3 DAP - Delivered At Place 08 - Jobsite (per IncoTerms 2020)  
See Freight Payment (Delivery Terms) below.

**Taxes:** State, local and other applicable taxes are not included in this quotation.





**Back Charges:** Buyer shall not make purchases nor shall Buyer incur any labor that would result in a back charge to Seller without prior written consent of an authorized employee of Seller.

**Shortages:** Xylem will not be responsible for apparent shipment shortages or damages incurred in shipment that are not reported within two weeks from delivery to the jobsite. Damages should be noted on the receiving slip and the truck driver advised of the damages. Please contact our office as soon as possible to report damages or shortages so that replacement items can be shipped and the appropriate claims made.

**Terms of Delivery:** PP/Add Order Position

**Terms of Payment:** 100% N60 after invoice date.

Xylem's payment shall not be dependent upon Purchaser being paid by any third party unless Owner denies payment due to reasons solely attributable to items related to the equipment being provided by FLYGT.

**Validity:** This Quote is valid for thirty (30) days.

**Schedule:** Please consult your local Flygt Branch Office to get fabrication and delivery lead times.

**COVID 19:** Our current delivery lead-times are forecasted estimates only due to the outbreak of the COVID-19 virus pandemic and its global effects on commerce, supply chain, and logistics. Xylem will, however, use all commercially reasonable efforts to minimize any delivery delay impacts.

**Warranty:** Xylem Water Solutions USA, Inc. offers a commercial warranty to the original end purchaser against defects in workmanship and material.

Thank you for the opportunity to provide this quotation. Please contact us if there are any questions.

Sincerely,

Steve Ellington  
Sales Representative

steve.ellington@xylem.com





**Xylem Water Solutions USA, Inc.  
Flygt Products**

**Customer Acceptance**

This order is subject to the Standard Terms and Conditions of Sale – Xylem Americas effective on the date the order is accepted which terms are available at <http://www.xylem.com/en-us/Pages/terms-conditions-of-sale.aspx> and incorporated herein by reference and made a part of the agreement between the parties.

A signed copy of this Quote is acceptable as a binding contract.

**Purchase Orders:** Please make purchase orders out to: Xylem Water Solutions USA, Inc.

Quote #: 2021-CIN-0816  
Customer Name: VLG OF ASHVILLE  
Job Name:  
Total Amount: \$ 19,465.25  
(excluding freight)

Signature: _____	Name: _____ (PLEASE PRINT)
Company/Utility: _____	PO: _____
Address: _____	Date: _____
_____	Phone: _____
_____	Email: _____
_____	Fax: _____



# APPENDIX E DEZURIK WARRANTY FOR EXISTING RAS AND WAS ACTUATORS



18817 S. H. 501 N., Box 2058, Wapakoneta, OH 45895-0558  
Phone: (419) 941-2233 Fax: (419) 941-2244  
[www.petersonconstruction.com](http://www.petersonconstruction.com)

PROJECT NAME:	VILLAGE OF ASHVILLE, OHIO WATER RESOURCE RECOVERY FACILITY IMPROVEMENTS 3219 STATE ROUTE 752 ASHVILLE, OHIO 43103
SPEC. SECTION:	400523
PRODUCT NAME:	PROCESS VALVES, GATES, AND ACCESSORIES
SUBCONTRACTOR:	RAWDON MYERS 300 MILFORD DRIVE MILFORD, OH 45150 513/965-5300



250 Riverside Ave N 320-269-2000 p  
Sartell, MN 56377 USA 320-269-2227 f

October 6, 2017

Mr. Matt Brackman  
Peterson Construction Company  
18817 State Route 501 North  
PO Box 2058  
Wapakoneta, OH 45895

Subject: Warranty Expiration Date  
Project: Ashville, OH WRRF  
DeZURIK Work Order No: 444293, 458734, 458735

Dear Mr. Brackman,

The warranty on the DeZURIK, APCO and Hilton BOS, PEC, PEF, CVS and ASU valves listed on the above work orders for the Ashville, OH WRRF project will be valid until October 6th of 2018, one year from the substantial completion date of October 6th of 2017. Our standard warranty covers any defects to materials supplied and workmanship of the valves which have been shipped and are on the job site for this project.

If you have any questions or require additional information, please contact Jim Steels with Rawdon Myers, Inc.

Sincerely,

Steve Symanietz  
Municipal Sales Support Manager  
DeZURIK, Inc.  
(320) 259-2355  
[steve.symanietz@dezurik.com](mailto:steve.symanietz@dezurik.com)

[info@dezurik.com](mailto:info@dezurik.com)  
[www.dezurik.com](http://www.dezurik.com)

Printed in the USA



**APPENDIX F**

**PETERSON CONSTRUCTION COMPANY PROPOSAL FEE FOR  
ACTUATOR REPLACEMENT**



18817 State Route 501 North, PO Box 2058, Wapakoneta, Ohio 45895  
 PH: 419-941-2233; Fax: 855-876-0921; [www.petersonconstructionco.com](http://www.petersonconstructionco.com)

May 17<sup>th</sup>, 2019

Via E-Mail

AECOM  
 277 West Nationwide Blvd  
 Columbus, OH 43215

ATTN: Brian Benedict

RE: Ashville WWTP  
 PCC Change Order Request No. 602-47A  
 "Valve Actuators"

Gentlemen:

The Owner has requested that we provide pricing to move the one motor actuator valves in valve vaults to the top of the vault (outside the structure). We are please to offer a price for this work in the amount of **\$21,915**.

Inclusions:

- Remove the 4" actuator in the WAS vault and furnish a new actuator to install on top of the vault with extension stem and floor stand. This actuator will not be explosion proof.
- Included electrical removal at the actuator and wiring the actuator in the new locations.
- Prevailing Wage
- Owner cooperation will be required to perform shut downs on the RAS and WAS lines. RAS wet well be need to be taken out of service for a short period of time.

Exclusions:

- Taxes
- Site restoration/seeding

Please issue a formal Change Order for the appropriate amount if this is acceptable to you.

Do not hesitate to call with any questions you may have.

Sincerely,  
 PETERSON CONSTRUCTION COMPANY

*Matt Brachman*



18817 State Route 501 North, PO Box 2058, Wapakoneta, Ohio 45395  
 PH: 419-941-2233, Fax: 855-876-0921, [www.petersonconstructionco.com](http://www.petersonconstructionco.com)

May 17<sup>th</sup>, 2019

Via E-Mail

AECOM  
 277 West Nationwide Blvd  
 Columbus, OH 43215

ATTN: Brian Benedict

RE: Ashville WWTP  
 PCC Change Order Request No. 602-47  
 "Valve Actuators"

Gentlemen:

The Owner has requested that we provide pricing to move the three motor actuator valves in valve vaults to the top of the vault (outside the structure). We are please to offer a price for this work in the amount of **\$39,845**.

Inclusions:

- Remove the 4" actuator in the WAS vault and furnish a new actuator to install on top of the vault with extension stem and floor stand. This actuator will not be explosion proof.
- Move both 6" actuators in the RAS vault to the top of the vault with extension stem and floor stand.
- Included electrical removal at the actuator and wiring the actuators in the new locations.
- Prevailing Wage
- Owner cooperation will be required to perform shut downs on the RAS and WAS lines. Drainage of the oxidation ditch splitter box and outer ring of oxidation ditch may be required.

Exclusions:

- Taxes
- Site restoration/seeding

Please issue a formal Change Order for the appropriate amount if this is acceptable to you.

Do not hesitate to call with any questions you may have.

Sincerely,  
 PETERSON CONSTRUCTION COMPANY

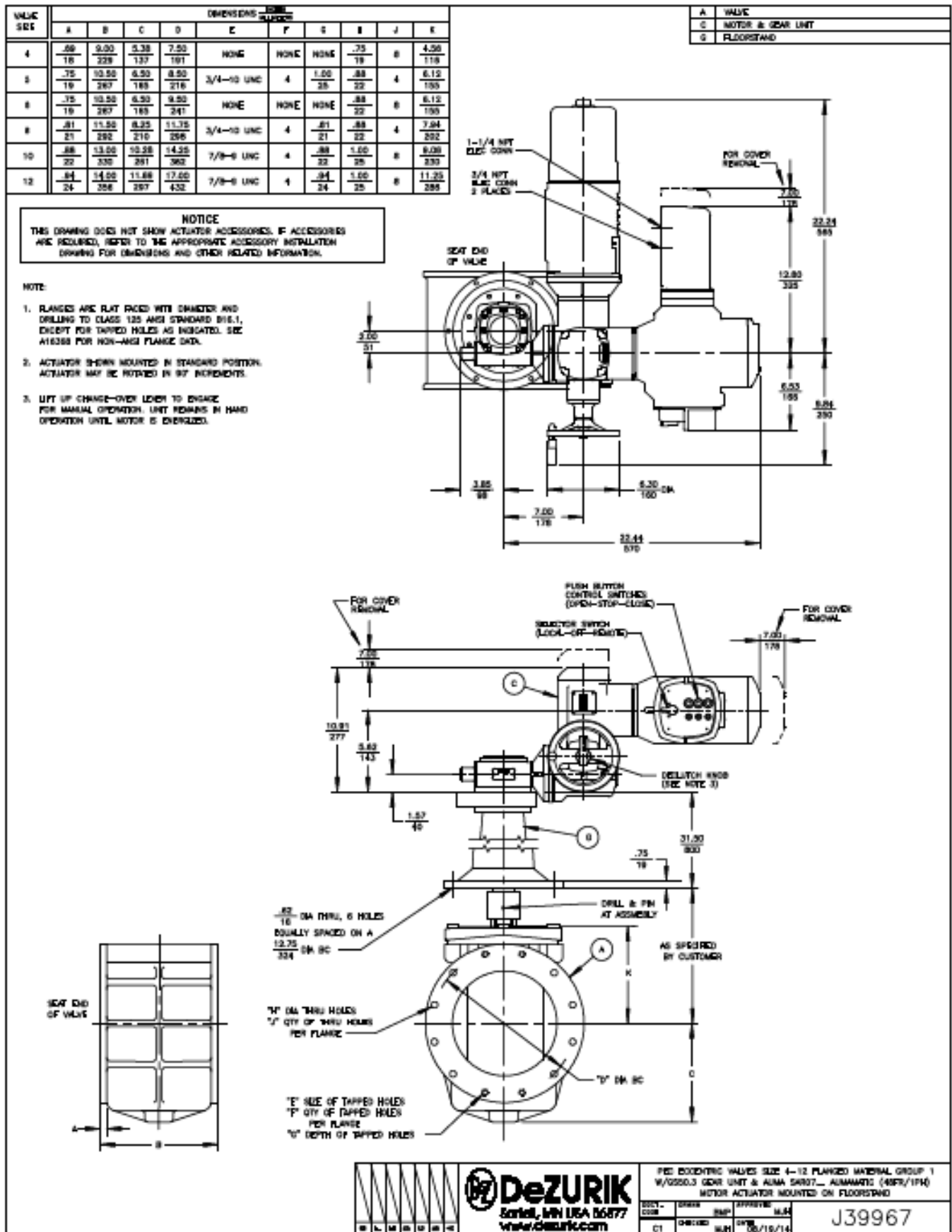



731.141 Village administrator to make contracts and purchases.

In those villages that have established the position of village administrator, as provided by section 735.271 of the Revised Code, the village administrator shall make contracts, purchase supplies and materials, and provide labor for any work under the administrator's supervision involving not more than fifty thousand dollars. When an expenditure, other than the compensation of persons employed by the village, exceeds fifty thousand dollars, the expenditure shall first be authorized and directed by ordinance of the legislative authority of the village. When so authorized and directed, except where the contract is for equipment, services, materials, or supplies to be purchased under division (D) of section 713.23 or section 125.04 or 5513.01 of the Revised Code, available from a qualified nonprofit agency pursuant to sections 4115.31 to 4115.35 of the Revised Code, or required to be purchased from a qualified nonprofit agency under sections 125.60 to 125.6012 of the Revised Code, the village administrator shall make a written contract with the lowest and best bidder after advertisement for not less than two nor more than four consecutive weeks in a newspaper of general circulation within the village or as provided in section 7.16 of the Revised Code. The bids shall be opened and shall be publicly read by the village administrator or a person designated by the village administrator at the time, date, and place as specified in the advertisement to bidders or specifications. The time, date, and place of bid openings may be extended to a later date by the village administrator, provided that written or oral notice of the change shall be given to all persons who have received or requested specifications no later than ninety-six hours prior to the original time and date fixed for the opening. All contracts shall be executed in the name of the village and signed on its behalf by the village administrator and the clerk.

The legislative authority of a village may provide, by ordinance, for central purchasing for all offices, departments, divisions, boards, and commissions of the village, under the direction of the village administrator, who shall make contracts, purchase supplies or materials, and provide labor for any work of the village in the manner provided by this section.

Cite as R.C. § 731.141 Amended by 129th General Assembly File No.141, HB 509, §1, eff. 9/28/2012. Amended by 129th General Assembly File No.28, HB 153, §101.01, eff. 9/29/2011. Effective Date: 09-26-2003; 10-21-2005



**Xylem Water Solutions USA, Inc.  
Flygt Products**

May 12, 2022

1615 State Route 131  
Milford, Ohio 45150  
Tel 513/831-7867  
Fax 513/831-7868

VLG OF ASHVILLE  
PO BOX 195  
ASHVILLE OH 43103-0195

Quote # 2022-CIN-0423  
Project Name: Ashville Influent Pump Station Quote  
Job Name:

Xylem Water Solutions USA, Inc. is pleased to provide a quote for the following Flygt equipment.

Influent Pump Station		
Qty	Part Number	Description
2	3153.185-0918	Flygt Model NP-3153.185 6" volute Submersible pump equipped with a 460 Volt / 3 phase / 60 Hz 15 HP 1750 RPM motor, 435 impeller, 1 x 50 Ft. length of SUBCAB 4G10+S(2x0,5) submersible cable, FLS leakage detector, volute is prepared for Flush Valve
1	14-69 00 09	START UP CHARGE FLYGT 1-TP MODELS: 3000,7000,8000
2	602 33 06	CONNECTION,DISCH 5½X6" CI
2	14-58 95 35	HARDWARE,DISC CONN ASSY 304SS
2	14-40 71 29	MINI-CASII/FUS 120/24VAC,24VDC
2	14-40 70 97	SOCKET,11 PIN OCTAL DIN MOUNT
2	613 68 04	BRACKET,GUIDE BAR UPPER 2" 316
2	14-58 42 52	BRACKET,INT GB 2 X 8" 316SS+ FOR CI/DI PIPE
		<b>Total Price \$ 53,492.00</b>
		<b>Freight Charge \$ 2,343.00</b>
		<b>Total Price \$ 55,835.00</b>

**Terms & Conditions**

This order is subject to the Standard Terms and Conditions of Sale – Xylem Americas effective on the date the order is accepted which terms are available at <http://www.xylem.com/en-us/Pages/terms-conditions-of-sale.aspx> and incorporated herein by reference and made a part of the agreement between the parties.

- Purchase Orders:** Please make purchase orders out to: Xylem Water Solutions USA, Inc.
- Freight Terms:** 3 DAP - Delivered At Place 08 - Jobsite (per IncoTerms 2020)  
See Freight Payment (Delivery Terms) below.
- Taxes:** State, local and other applicable taxes are not included in this quotation.
- Back Charges:** Buyer shall not make purchases nor shall Buyer incur any labor that would result in a back charge to Seller without prior written consent of an authorized employee of Seller.



- Shortages:** Xylem will not be responsible for apparent shipment shortages or damages incurred in shipment that are not reported within two weeks from delivery to the jobsite. Damages should be noted on the receiving slip and the truck driver advised of the damages. Please contact our office as soon as possible to report damages or shortages so that replacement items can be shipped and the appropriate claims made.
- Terms of Delivery:** PP/Add Order Position
- Terms of Payment:** 100% N60 after invoice date.  
 Xylem's payment shall not be dependent upon Purchaser being paid by any third party unless Owner denies payment due to reasons solely attributable to items related to the equipment being provided by FLYGT.
- Validity:** This Quote is valid for thirty (30) days.  
 Please note that this pricing is valid for 30 days and contingent upon final approval of submittals and release to fabrication by (within 90 days of bid date).  
 This quotation is subject to change if any changes to the specifications or plans are made that alter the scope of supply.
- Schedule:** Please consult your local Flygt Branch Office to get fabrication and delivery lead times.
- COVID 19:** Our current delivery lead-times are forecasted estimates only due to the outbreak of the COVID-19 virus pandemic and its global effects on commerce, supply chain, and logistics. Xylem will, however, use all commercially reasonable efforts to minimize any delivery delay impacts.
- Warranty:** Xylem Water Solutions USA, Inc. offers a commercial warranty to the original end purchaser against defects in workmanship and material.

Thank you for the opportunity to provide this quotation. Please contact us if there are any questions.

Sincerely,

Steve Ellington  
 Sales Representative

steve.ellington@xylem.com







**Xylem Water Solutions USA, Inc.  
Flygt Products**

**Customer Acceptance**

This order is subject to the Standard Terms and Conditions of Sale – Xylem Americas effective on the date the order is accepted which terms are available at <http://www.xylem.com/en-us/Pages/terms-conditions-of-sale.aspx> and incorporated herein by reference and made a part of the agreement between the parties.

A signed copy of this Quote is acceptable as a binding contract.

**Purchase Orders:** Please make purchase orders out to: Xylem Water Solutions USA, Inc.

Quote #: 2022-CIN-0423  
Customer Name: VLG OF ASHVILLE  
Job Name:  
Total Amount: \$ 53,492.00  
(excluding freight)

Signature: _____	Name: _____ (PLEASE PRINT)
Company/Utility: _____	PO: _____
Address: _____	Date: _____
_____	Phone: _____
_____	Email: _____
_____	Fax: _____



www.dezurik.com

**DeZURIK  
Quotation**

**Rawdon  
Myers, Inc.**

**To:** ASHVILLE WWTP  
USA  
**Invoice Terms:** Net 30 Days  
**Days Valid:** 0  
**Shipping Point:** NO CHARGE - INCLUDED  
**Delivery Notes:**

**Date of Quote:** 05-16-2022  
**Quote Number:** 271113  
**Project Name:** Ashville Ohio Retrofit  
**I.D. (Rep. Use):** 701  
**Line of Business:** 4952 - Municipal Sewage Treatment  
**Make Order To:** Rawdon Myers, Inc.  
Jim Steele Municipal Treatment Sales  
300 Milford Parkway  
Milford, OH 45150  
USA  
Phone 513 965 5300  
Fax 513 965 5314  
Email JimS@rawdonmyers.com

Currency and Values expressed in USD (\$)

Line #	Cust. Line # Tag #	Qty	Order Code	Unit Price	Total Price
1	EXISTING VALVE REMAINS REPLACE ELECTRIC ACTUATOR AND ADD FLOORSTAND, EXTENSION STEM AND STEM GUIDE - INCLUDES SHIPPING COSTS AND I STARTUP TRIP FOR THE NEW INSTALLATION	2	PEC,6,F1,CI,NBR,CR*X,FSTS Modified <b>PEC:</b> Style - DeZURIK Eccentric Plug Valve, Rectangular Port (AWWA C517) <b>6:</b> Size - 6 Inch (150mm); (Standard Port), Stainless Steel Bearings, Welded-In Nickel Seat (Except Rubber Lined or Stainless Steel Bodies) <b>F1:</b> End Connection - Flanged, Drilled to ASME Class 125/150 <b>CI:</b> Body Material - Cast Iron, ASTM A126, Class B; (.5"-12" Pressure Rating 175 psi (1210 kPa); (14" & larger Pressure Rating 150 psi (1030 kPa) <b>NBR:</b> Packing - .5" - 3" Acrylonitrile-Butadiene Reinforced filler in a PTFE U-ring, -20 to 180° F. (-29 to 83° C.); 4" & Larger Acrylonitrile-Butadiene Reinforced V-type, -20 to 250° F. (-29 to 121° C.) <b>CR:</b> Plug Facing - Chloroprene; -20 to 180°F (-29 to 83°C) <b>Coating or Paint:</b> SB0 - 4 mils minimum (non-stainless steel parts) of Blue DeZURIK Epoxy (NSF Std. 61) on Exterior with Standard (SP10) surface prep <b>X:</b> Actuator Type - AUMA ELECTRIC ACTUATOR <b>FSTS:</b> Accessories - Actuator mounted on Floorstand; Steel Extension <b>13:</b> Length - 13 Feet <b>5:</b> Length - 5 Feet	\$11,180.00	\$22,360.00
2		2	TBD STEM GUIDE	\$450.00	\$900.00
<b>Total</b>					\$23,260.00



PO Box 210  
 16460 State Route 180  
 Laurelvile OH 43135  
 Phone (740) 332-3903  
 Fax (740) 332-3907  
 E-mail bjselectricinc@yahoo.com

# Estimate

Date	Estimate #
5/16/2022	5150

### Name / Address

Village of Ashville  
 200 East Station St.  
 Ashville, OH 43103

*Thank you for the opportunity  
 to provide you with an  
 estimate for our services.*

Description	P.O. No.		Project	
	Qty	Total		
Total for all estimates				
Replace VFD cable (5141)		50,817.00		
Replace underground to lift station (5142)		11,397.56		
Replace 2 fan motor for exhaust (5143)		525.00		
Repair purafil (5144)		1,000.00		
Relabel panel (5145)		175.00		
Replace fiber lines (5146)		35,000.00		
Replace 4ft washdown lights (5147)		1,475.00		
Replace switch in sludge press building (5148)		3,285.12		
<b>Total</b>				<b>\$103,674.68</b>

Please Note:  
 We reserve the right to charge a 1.5% SERVICE CHARGE at an annual rate of 18%.

ACCEPTED: Visa Mastercard Discover

OH LIC# 25778





PO Box 210  
 18460 State Route 180  
 Laurelville OH 43135  
 Phone (740) 332-3903  
 Fax (740) 332-3907  
 E-mail bjselectricinc@yahoo.com

# Estimate

Date	Estimate #
5/16/2022	5141

### Name / Address

Village of Ashville  
 200 East Station St.  
 Ashville, OH 43103

*Thank you for the opportunity  
 to provide you with an  
 estimate for our services.*

		P.O. No.	Project
Description		Qty	Total
This is an estimate for the following electrical service(s):			
<p>**We recommend replacing VFD cable due to improper VFD cable being installed by originally electrician.                      **At each location there should be an AUX switch with the existing disconnects which should be connected to the VFD to not cause damage to the drives. The cable should be shielded to unlimited the interface thru out your electrical system.</p> <ul style="list-style-type: none"> <li>- Install VFD cable on RAS pump 1 &amp; 2. Runs of #6 with 4 pair shielded cable</li> <li>- Sludge transfer pumps 1 &amp; 2</li> <li>- Sludge press</li> <li>- Sludge press drives 1 &amp; 2</li> <li>- Polymer pump/ repair sola power supply</li> </ul>			25,672.00 12,727.00 6,082.50 5,660.50 675.00
<p>NOTES:</p> <ul style="list-style-type: none"> <li>* Estimate includes all wiring &amp; installation to be in accordance with NEC.</li> <li>* Estimate includes above scope of work only. Any work beyond or requiring additional services will be at an additional cost.</li> <li>* Estimate does not include cutting, patching or painting of walls, drives, roads, etc. unless mentioned above.</li> <li>* Estimate includes all work to be performed during normal business hours.</li> <li>* Due to raw material shortages, supply chain issues, market volatility, OEM manufacturing problems and shipping delays, please note the following:                         <ul style="list-style-type: none"> <li>- BJ's Electric cannot guarantee pricing for any project beyond 10 days from the date of this estimate. Any estimates accepted beyond this timeframe may be subjected to price increase based on current supplier pricing.</li> <li>- Equipment Manufacturers are experiencing delivery delays on nearly all product lines. BJ's Electric will not be held responsible for any failure to meet project deadlines due to supply chain issues beyond our control.</li> </ul> </li> </ul> <p style="text-align: center;">*** Any questions please contact Brad Jones 740-207-5827 ***</p>			
<p>Please Note:                      We reserve the right to charge a 1.5% SERVICE CHARGE at an annual rate of 18%.</p>		<b>Total</b>	<b>\$50,817.00</b>

ACCEPTED: Visa Mastercard Discover

OH LIC# 25778



PO Box 210  
 16460 State Route 180  
 Laurelville OH 43135  
 Phone (740) 332-3903  
 Fax (740) 332-3907  
 E-mail bjselectricinc@yahoo.com

# Estimate

Date	Estimate #
5/16/2022	5142

### Name / Address

Village of Ashville  
 200 East Station St.  
 Ashville, OH 43103

*Thank you for the opportunity  
 to provide you with an  
 estimate for our services.*

This estimate is only valid for 10 days.

Description	P.O. No.	Project
This is an estimate for the following electrical service(s):  BASE BID: - Replace underground to lift station  NOTES: * Estimate includes all wiring & installation to be in accordance with NEC. * Estimate includes above scope of work only. Any work beyond or requiring additional services will be at an additional cost. * Estimate does not include cutting, patching or painting of walls, drives, roads, etc. unless mentioned above. * Estimate includes all work to be performed during normal business hours. * Due to raw material shortages, supply chain issues, market volatility, OEM manufacturing problems and shipping delays, please note the following: - BJ's Electric cannot guarantee pricing for any project beyond 10 days from the date of this estimate. Any estimates accepted beyond this timeframe may be subjected to price increase based on current supplier pricing. - Equipment Manufacturers are experiencing delivery delays on nearly all product lines. BJ's Electric will not be held responsible for any failure to meet project deadlines due to supply chain issues beyond our control.  *** Any questions please contact Brad Jones 740-207-5827 ***	Qty	Total
		11,397.56
Please Note: We reserve the right to charge a 1.5% SERVICE CHARGE at an annual rate of 18%.	<b>Total</b>	<b>\$11,397.56</b>

ACCEPTED: Visa Mastercard Discover

OH LIC# 25778



PO Box 210  
 16460 State Route 180  
 Laurelvile OH 43135  
 Phone (740) 332-3903  
 Fax (740) 332-3907  
 E-mail bjelectricinc@yahoo.com

# Estimate

Date	Estimate #
5/16/2022	5144

### Name / Address

Village of Ashville  
 200 East Station St.  
 Ashville, OH 43103

*Thank you for the opportunity to provide you with an estimate for our services.*

This estimate is only valid for 10 days.

P.O. No.	Project

Description	Qty	Total
<p>This is an estimate for the following electrical service(s):</p> <p>BASE BID:                      - Repair parafil</p> <p>NOTES:                      * Estimate includes all wiring &amp; installation to be in accordance with NEC.                      * Estimate includes above scope of work only. Any work beyond or requiring additional services will be at an additional cost.                      * Estimate does not include cutting, patching or painting of walls, drives, roads, etc, unless mentioned above.                      * Estimate includes all work to be performed during normal business hours.                      * Due to raw material shortages, supply chain issues, market volatility, OEM manufacturing problems, and shipping delays, please note the following:                      - BJ's Electric cannot guarantee pricing for any project beyond 10 days from the date of this estimate. Any estimates accepted beyond this timeframe may be subjected to price increase based on current supplier pricing.                      - Equipment Manufacturers are experiencing delivery delays on nearly all product lines. BJ's Electric will not be held responsible for any failure to meet project deadlines due to supply chain issues beyond our control.</p> <p style="text-align: center;">*** Any questions please contact Brad Jones 740-207-5827 ***</p>		1,000.00

Please Note:  
 We reserve the right to charge a 1.5% SERVICE CHARGE at an annual rate of 18%.

<b>Total</b>	<b>\$1,000.00</b>
--------------	-------------------

ACCEPTED: Visa    Mastercard    Discover

OH LIC# 25778





PO Box 210  
 16460 State Route 180  
 Laurelville OH 43135  
 Phone (740) 332-3903  
 Fax (740) 332-3907  
 E-mail bjselectricinc@yahoo.com

# Estimate

Date	Estimate #
5/16/2022	5145

### Name / Address

Village of Ashville  
 200 East Station St.  
 Ashville, OH 43103

*Thank you for the opportunity  
 to provide you with an  
 estimate for our services.*

		P.O. No.	Project
Description	Qty	Total	
This is an estimate for the following electrical service(s):  BASE BID: - Refabel panel  NOTES: * Estimate includes all wiring & installation to be in accordance with NEC. * Estimate includes above scope of work only. Any work beyond or requiring additional services will be at an additional cost. * Estimate does not include cutting, patching or painting of walls, drives, roads, etc. unless mentioned above. * Estimate includes all work to be performed during normal business hours. * Due to raw material shortages, supply chain issues, market volatility, OEM manufacturing problems and shipping delays, please note the following: - BJ's Electric cannot guarantee pricing for any project beyond 10 days from the date of this estimate. Any estimates accepted beyond this timeframe may be subjected to price increase based on current supplier pricing. - Equipment Manufacturers are experiencing delivery delays on nearly all product lines. BJ's Electric will not be held responsible for any failure to meet project deadlines due to supply chain issues beyond our control.			175.00
Please Note: We reserve the right to charge a 1.5% SERVICE CHARGE at an annual rate of 18%.		<b>Total</b> \$175.00	

ACCEPTED: Visa    Mastercard    Discover

OH LIC# 25778



PO Box 210  
 16460 State Route 180  
 Laurelville OH 43135  
 Phone (740) 332-3903  
 Fax (740) 332-3907  
 E-mail bjselectricinc@yahoo.com

# Estimate

Date	Estimate #
5/16/2022	5146

### Name / Address

Village of Ashville  
 200 East Station St.  
 Ashville, OH 43103

*Thank you for the opportunity  
 to provide you with an  
 estimate for our services.*

P.O. No.	Project

Description	Qty	Total
This an estimate for the following electrical service(s):  BASE BID: - Replace bad fiber lines  NOTES: * Estimate includes all wiring & installation to be in accordance with NEC. * Estimate includes above scope of work only. Any work beyond or requiring additional services will be at an additional cost. * Estimate does not include cutting, patching or painting of walls, drives, roads, etc. unless mentioned above. * Estimate includes all work to be performed during normal business hours. * Due to raw material shortages, supply chain issues, market volatility, OEM manufacturing problems and shipping delays, please note the following: - BJ's Electric cannot guarantee pricing for any project beyond 10 days from the date of this estimate. Any estimates accepted beyond this timeframe may be subjected to price increase based on current supplier pricing. - Equipment Manufacturers are experiencing delivery delays on nearly all product lines. BJ's Electric will not be held responsible for any failure to meet project deadlines due to supply chain issues beyond our control.		35,000.00

Please Note:  
 We reserve the right to charge a 1.5% SERVICE CHARGE at an annual rate of 18%.

<b>Total</b>	<b>\$35,000.00</b>
--------------	--------------------

ACCEPTED: Visa    Mastercard    Discover

OH LIC# 25778



PO Box 210  
 16460 State Route 180  
 Laurelville OH 43135  
 Phone (740) 332-3803  
 Fax (740) 332-3907  
 E-mail bjselectricinc@yahoo.com

# Estimate

Date	Estimate #
5/16/2022	5147

**Name / Address**

Village of Ashville  
 200 East Station St.  
 Ashville, OH 43103

*Thank you for the opportunity  
 to provide you with an  
 estimate for our services.*

P.O. No.	Project

Description	Qty	Total
This an estimate for the following electrical service(s):  BASE BID: - Replace or repair (4) 4ft wash downs  NOTES: * Estimate includes all wiring & installation to be in accordance with NEC. * Estimate includes above scope of work only. Any work beyond or requiring additional services will be at an additional cost. * Estimate does not include cutting, patching or painting of walls, drives, roads, etc. unless mentioned above. * Estimate includes all work to be performed during normal business hours. * Due to raw material shortages, supply chain issues, market volatility, OEM manufacturing problems and shipping delays, please note the following: - BJ's Electric cannot guarantee pricing for any project beyond 10 days from the date of this estimate. Any estimates accepted beyond this timeframe may be subjected to price increase based on current supplier pricing. - Equipment Manufacturers are experiencing delivery delays on nearly all product lines. BJ's Electric will not be held responsible for any failure to meet project deadlines due to supply chain issues beyond our control.		1,475.00

Please Note:  
 We reserve the right to charge a 1.5% SERVICE CHARGE at an annual rate of 18%.

<b>Total</b>	<b>\$1,475.00</b>
--------------	-------------------

ACCEPTED: Visa Mastercard Discover

OH LIC# 25778





PO Box 210  
 16460 State Route 180  
 Laurelville OH 43135  
 Phone (740) 332-3903  
 Fax (740) 332-3907  
 E-mail bjselectricinc@yshoo.com

# Estimate

Date	Estimate #
5/16/2022	5148

**Name / Address**

Village of Ashville  
 200 East Station St.  
 Ashville, OH 43103

*Thank you for the opportunity  
 to provide you with an  
 estimate for our services.*

P.O. No.	Project

Description	Qty	Total
This is an estimate for the following electrical service(s):		
BASE BID: - Replace and relocate switch in sluge press building		3,285.12
NOTES: * Estimate includes all work to be performed during normal business hours. * Estimate includes all wiring & installation to be in accordance with NEC * Estimate includes above scope of work only. Any work beyond or requiring additional services will be at an additional cost. * Estimate does not include cutting, patching or painting of walls, drives, roads, etc. unless mentioned above. * Due to raw material shortages, supply chain issues, market volatility, OEM manufacturing problems and shipping delays, please note the following: - BJ's Electric cannot guarantee pricing for any project beyond 10 days from the date of this estimate. Any estimates accepted beyond this timeframe may be subjected to price increase based on current supplier pricing. - Equipment Manufacturers are experiencing delivery delays on nearly all product lines. BJ's Electric will not be held responsible for any failure to meet project deadlines due to supply chain issues beyond our control.		

Please Note:  
 We reserve the right to charge a 1.5% SERVICE CHARGE at an annual rate of 18%.

<b>Total</b>	<b>\$3,285.12</b>
--------------	-------------------

ACCEPTED: Visa Mastercard Discover

OH LIC# 25778