

PIC - SR-SR 316/SR 752-13.05/00.000  
 200143 PID - 107824  
 Dist 6 3/12/2020

Contract Proposal Available @  
 www.contracts.dot.state.oh.us/home

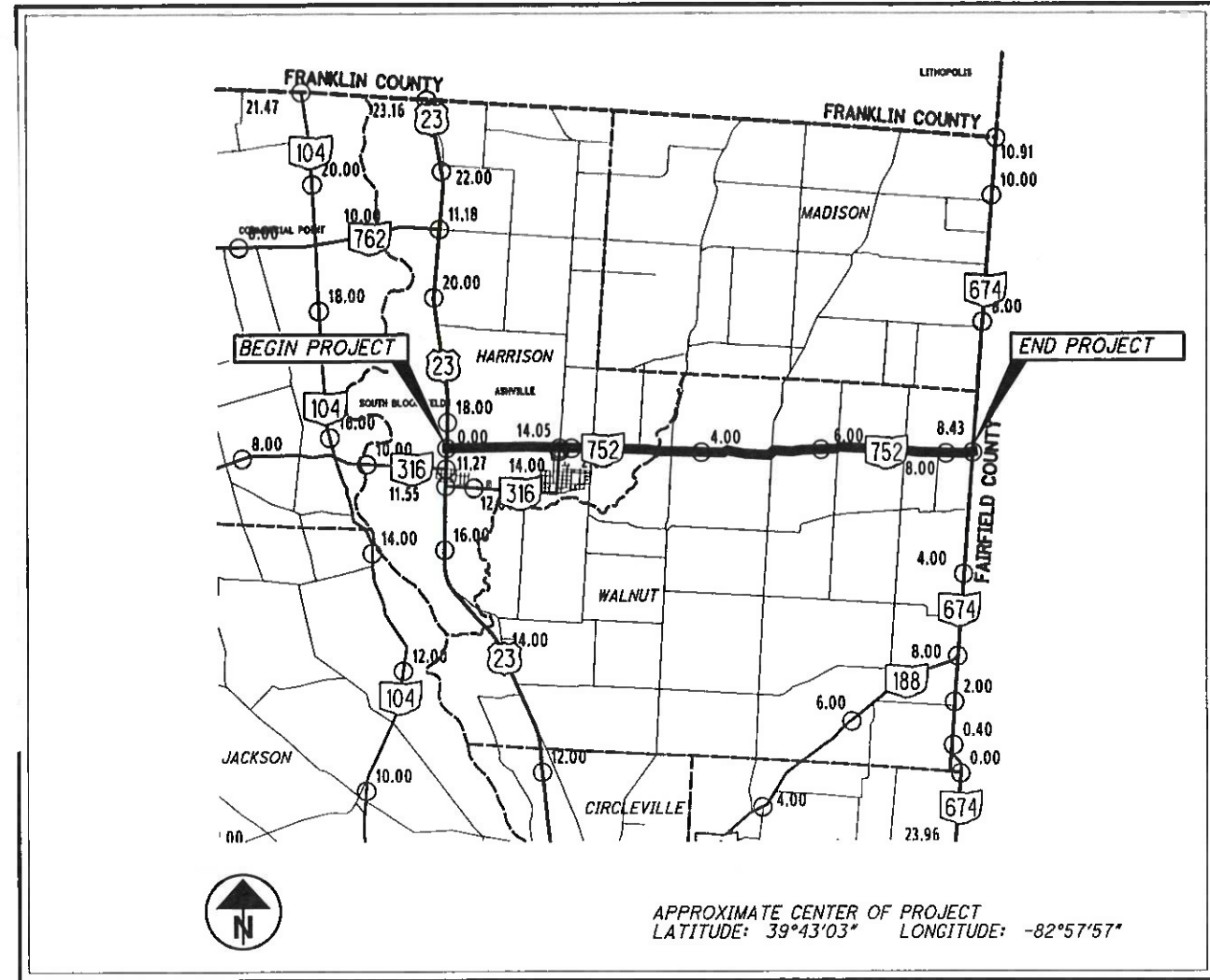

STATE OF OHIO  
 DEPARTMENT OF TRANSPORTATION

**PIC-316 / 752-13.05 / 0.00**  
**PART 1**

VILLAGE OF ASHVILLE  
 HARRISON AND WALNUT TOWNSHIPS  
 PICKAWAY COUNTY

FOR PART 2, SEE PIC-316 - 13.05-13.68

INDEX OF SHEETS

TITLE	1
SCHEMATIC PLAN	2
TYPICAL SECTION	3
TYPICAL DETAILS	4 - 6
GENERAL NOTES	7 - 9
MAINTENANCE OF TRAFFIC NOTES	10 - 11
GENERAL SUMMARY	12
PAVEMENT SUBSUMMARY	13
PAVEMENT REPAIR SUBSUMMARY	14 - 15
INTERSECTION DETAILS	16 - 17
GUARDRAIL DETAILS	18 - 19
GUARDRAIL SUBSUMMARY	20
GUARDRAIL PLAN	21 - 25
TRAFFIC CONTROL SUBSUMMARY	26 - 27
TRAFFIC CONTROL PLAN (NO PASSING)	28 - 32
STRUCTURE PLAN	33 - 36

PROJECT DESCRIPTION

THIS PROJECTS CONSISTS OF PAVEMENT REPAIRS AND PAVEMENT PLANING/RESURFACING ON SR 316 AND SR 752 IN PICKAWAY COUNTY. ALSO INCLUDED ARE GUARDRAIL AND MINOR BRIDGE WORK.

2019 SPECIFICATIONS

THE STANDARD SPECIFICATIONS OF THE STATE OF OHIO, DEPARTMENT OF TRANSPORTATION, INCLUDING SUPPLEMENTAL SPECIFICATIONS LISTED IN THE PLANS AND CHANGES LISTED IN THE PROPOSAL SHALL GOVERN THIS PROJECT.

I HEREBY APPROVE THESE PLANS AND DECLARE THAT THE MAKING OF THIS IMPROVEMENT WILL NOT REQUIRE THE CLOSING TO TRAFFIC OF THE HIGHWAY AND THAT PROVISIONS FOR THE MAINTENANCE OF TRAFFIC AND SAFETY WILL BE AS SET FORTH ON PLANS AND ESTIMATES.

DESIGN DESIGNATION  
 SEE LOCATION MAPS SHEETS 2

EARTH DISTURBED AREA:

PROJECT EARTH DISTURBED AREA N/A\*  
 EST. CONTRACTOR EARTH DISTURBED AREA N/A\*  
 NOTICE OF INTENT EARTH DISTURBED AREA N/A\*  
 \* MAINTENANCE PROJECT

**UNDERGROUND UTILITIES**  
 Contact Two Working Days Before You Dig

**OHIO811.org**  
 Before You Dig

OHIO811, 8-1-1, or 1-800-362-2764  
 (Non-members must be called directly)



ENGINEERS SEAL:	STANDARD CONSTRUCTION DRAWINGS						SUPPLEMENTAL SPECIFICATIONS			
	ODOT			CITY OF COLUMBUS						
 SIGNED: [Signature] DATE: 12.12.19	BP 3.1	07/18/14	TC 41.20	10/18/13	DM 1.2	01/18/13	2150	04/30/18	800	01/17/20
	BP 4.1	07/19/13	TC 41.30	10/18/13	DM 2.1	01/18/13	2319	03/30/18	832	10/19/18
	BP 5.1	07/20/18	TC 42.20	10/18/13	DM 4.4	01/15/16			897	01/16/15
	BP 7.1	07/20/18	TC 52.10	10/18/13						
			TC 52.20	07/20/18	MGS-1.1	01/19/18				
	MT 97.10	04/19/19	TC 61.30	01/20/17	MGS-2.1	01/19/18				
	MT 97.11	01/20/17	TC 65.10	01/17/14	MGS-2.3	07/18/14				
	MT 97.12	01/20/17	TC 65.11	07/21/17	MGS-4.3	01/18/13				
	MT 97.20	04/19/19	TC 71.10	01/19/18	MGS-5.2	07/15/16				
	MT 99.20	04/19/19			MGS-5.3	07/15/16				
	MT 101.90	07/21/17	MH 1.2	01/15/16	MGS-6.1	01/19/18				
	MT 105.10	07/19/13								
	MT 110.10	07/19/13	CB 1.1	07/19/19						
			CB 2.2	07/20/18						

APPROVED: [Signature] DISTRICT DEPUTY DIRECTOR  
 DATE: 12/12/19

APPROVED: [Signature] DIRECTOR, DEPARTMENT OF TRANSPORTATION  
 DATE: 1/14/20

FEDERAL PROJECT NO. E190(151)  
 PID NO. 107824  
 CONSTRUCTION PROJECT NO.  
 RAILROAD INVOLVEMENT  
 NORFOLK SOUTHERN  
 PIC-SR 316 / 752-13.05 / 0.00  
 1/36

CALCULATED  
XXX  
CHECKED  
XXX

0 0.25 0.5  
HORIZONTAL  
SCALE IN MILES

LOCATION MAP

PIC-SR 316 / 752-  
13.05 / 0.00

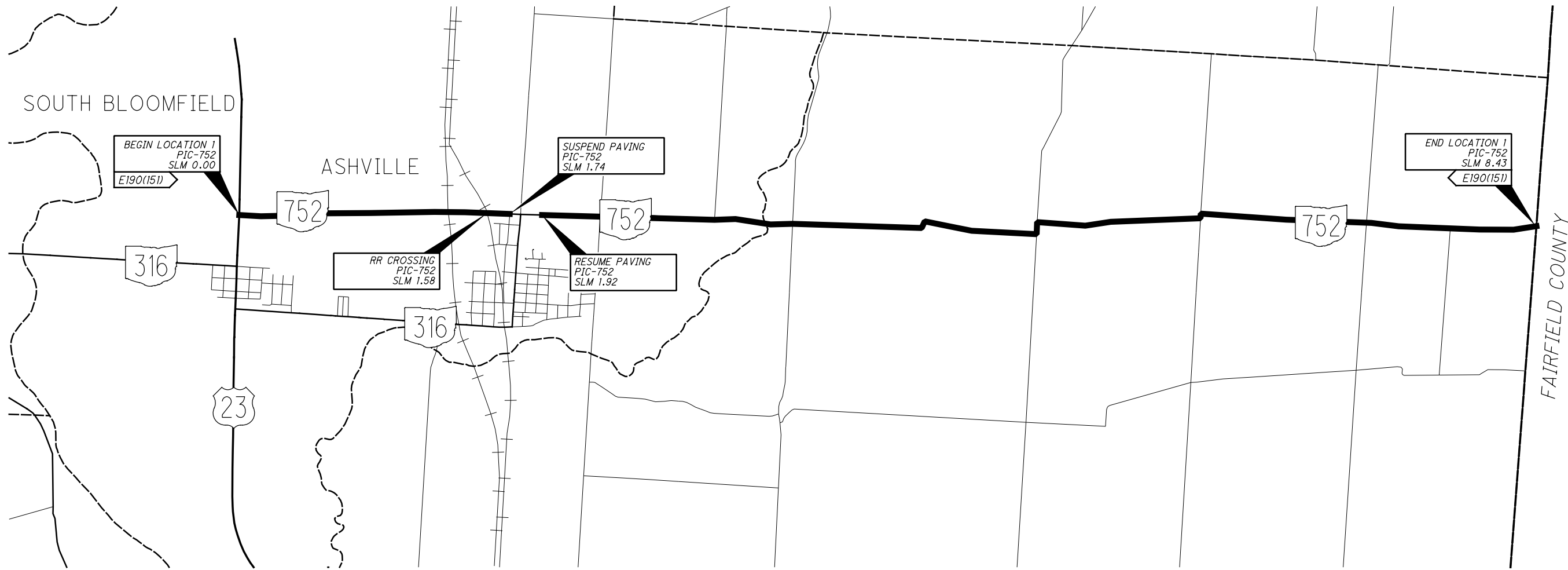

**PIC-752**  
(0.00-8.43)

OPENING DAY ADT (2020)	5200
DESIGN YEAR ADT (2032)	6300
TRUCKS (24 HOUR B&C)	364
DESIGN SPEED	55
LEGAL SPEED	35
DESIGN FUNCTIONAL CLASSIFICATION:	
MAJOR COLLECTOR (RURAL)	
NHS	NO

CATEGORY	GROUP	RESPONSIBLE ENTITY	PLAN SPLIT CODE	DESCRIPTION
STP<200000	PAVEMENT	STATE	01/S<2/PV	PIC-316-13.05 TO 13.68, PIC-752-0.00 TO 1.74, PIC 1.92 TO 2.32
STP RURAL	PAVEMENT	STATE	02/STR/PV	PIC-752-2.32 TO 8.43
STP RURAL	BRIDGE	STATE	03/STR/BR	BRIDGE ON PIC-752, SFN: 6503675
STP<200000	PAVEMENT	STATE	04/S<2/PV	PART 2 - PIC-316-13.06-13.68 - STATE FUNDED PAVING WORK
STP<200000	PAVEMENT	NON-STATE	04/S<2/PV	ITEMS TO BE PAID 100% BY THE VILLAGE OF ASHVILLE INCLUDING OPWC FUNDS

I:\Project+Data\07824\_PIC-316-13.05\Design\Roadway\Sheets\GB\_001.dgn 6B\_001 12/16/2019 2:48:11 PM rmcneill

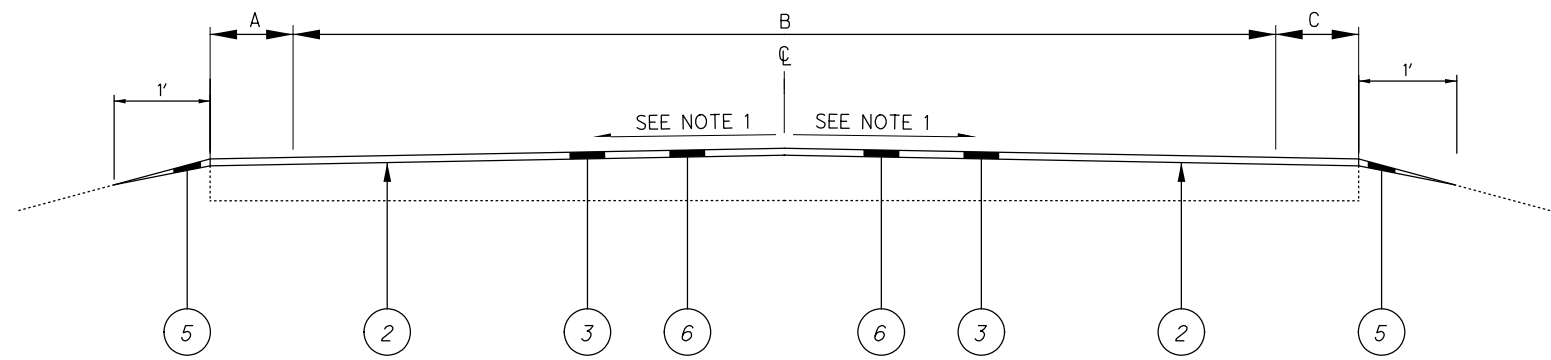

**TYPICAL #1**

LOC 1	PIC 752	0.05	TO	1.74	=	1.69
		1.92	TO	2.27	=	0.35
		2.37	TO	4.28	=	1.91
		4.50	TO	5.09	=	0.59
		5.27	TO	6.22	=	0.95
		6.35	TO	8.38	=	2.03

**LEGEND**

- ① ITEM 254 - PAVEMENT PLANING, ASPHALT CONCRETE, (3" DEPTH)
- ② ITEM 407 - NON-TRACKING TACK COAT (RATE PER CMS TABLE 407.06-1)
- ③ ITEM 424 - FINE GRADED POLYMER ASPHALT CONCRETE, TYPE B (1" DEPTH)
- ④ ITEM 442 - ASPHALT CONCRETE SURFACE COURSE, 12.5MM, TYPE A, PG76-22M (3" DEPTH, 2 LIFTS)
- ⑤ ITEM 617 - COMPACTED AGGREGATE (AVERAGE 2" DEEP x 1' WIDE)
- ⑥ ITEM 897 - PAVEMENT PLANING, ASPHALT CONCRETE, CLASS A (1" DEPTH)

NOTE 1:  
PAVEMENT CROSS SLOPES TO BE MAINTAINED.

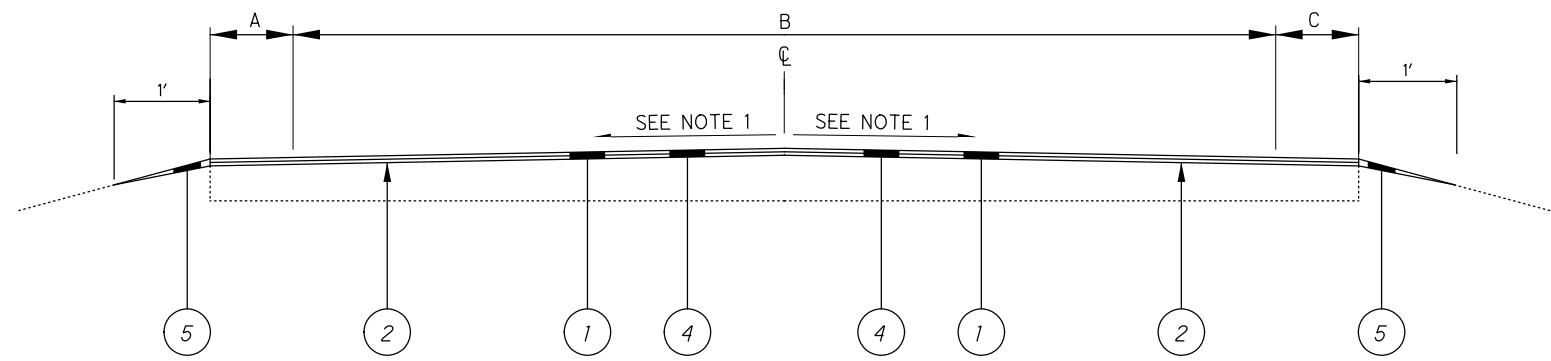

**TYPICAL #1**

LOC 1	PIC 752	0.00	TO	0.05	=	0.05
		2.27	TO	2.37	=	0.10
		4.28	TO	4.50	=	0.22
		5.09	TO	5.27	=	0.18
		6.22	TO	6.35	=	0.13
		8.38	TO	8.43	=	0.05

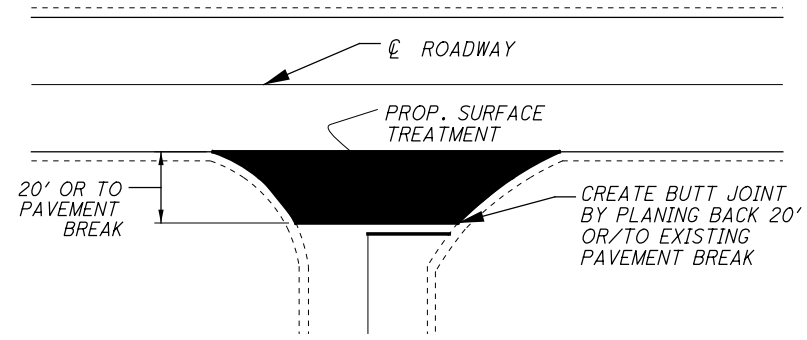

**TYPICAL INTERSECTION DETAIL**

■ MATCH PROPOSED PAVEMENT PLANING AND SURFACE TREATMENT DEPTH. TRANSITION TO BUTT JOINT. (BP 3.1)

LOC 1	PIC	752	SLM	0.00	US 23	US-23	BEGIN PROJECT
				2.32	TR 31	LOCKBOURNE EASTERN RD	LT
				2.32	TR 31	CIRCLEVILLE AVE	RT
				3.06	TR 96	HOOVER RD	LT
				3.54	CR 7	WALNUT CREEK PIKE	LT & RT (NORTH SIDE, MATCH PAVEMENT BREAK)
				5.14	TR 8	WINCHESTER RD	RT
				5.22	TR 8	WINCHESTER RD	LT
				6.27	TR 84	ETT NOECHER RD	RT
				6.30	TR 84	ETT NOECHER RD	LT
				7.36	TR 43	RINGGOLD NORTHERN RD	LT & RT (SOUTH SIDE, MATCH PAVEMENT BREAK)
				7.88	TR 86	PLAZIER RD	RT
				8.43	SR 674	SR-674	END PROJECT

I:\Project+Data\07824\_PIC-316-13.05\Design\Roadway\Sheets\GA\_001.dgn GA\_001 12/16/2019 2:48:13 PM rmcneill

CALCULATED  
RAM  
CHECKED  
XXX

**TYPICAL DETAILS**

PIC-SR 316 / 752 -  
13.05 / 0.00

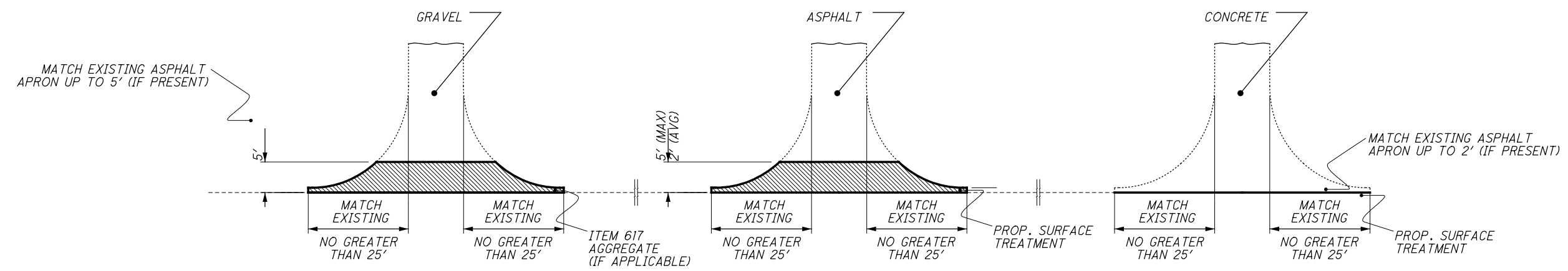

**TYPICAL DRIVEWAY APPROACH DETAILS**

MATCH PROPOSED PAVEMENT PLANING AND SURFACE TREATMENT DEPTH.

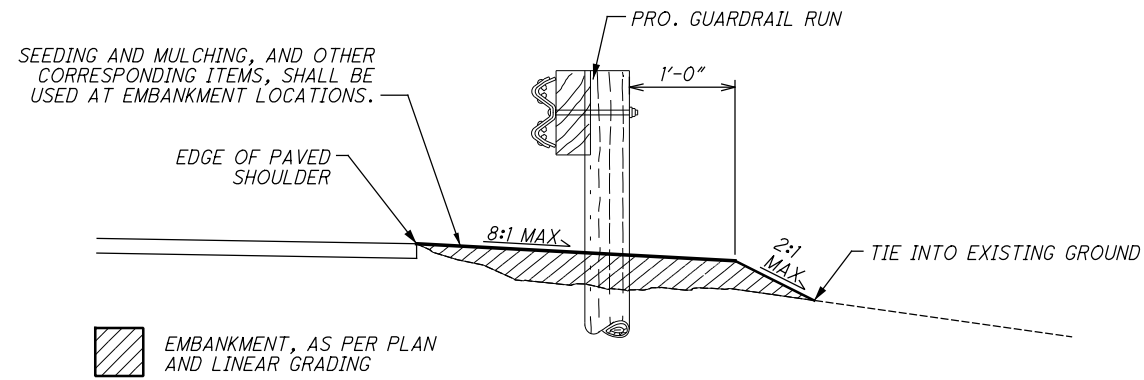

**GUARDRAIL DETAIL 1  
SECTION A-A**

SEE STANDARD DRAWING MGS-1.1  
FOR MORE DETAILS AND DIMENSIONS

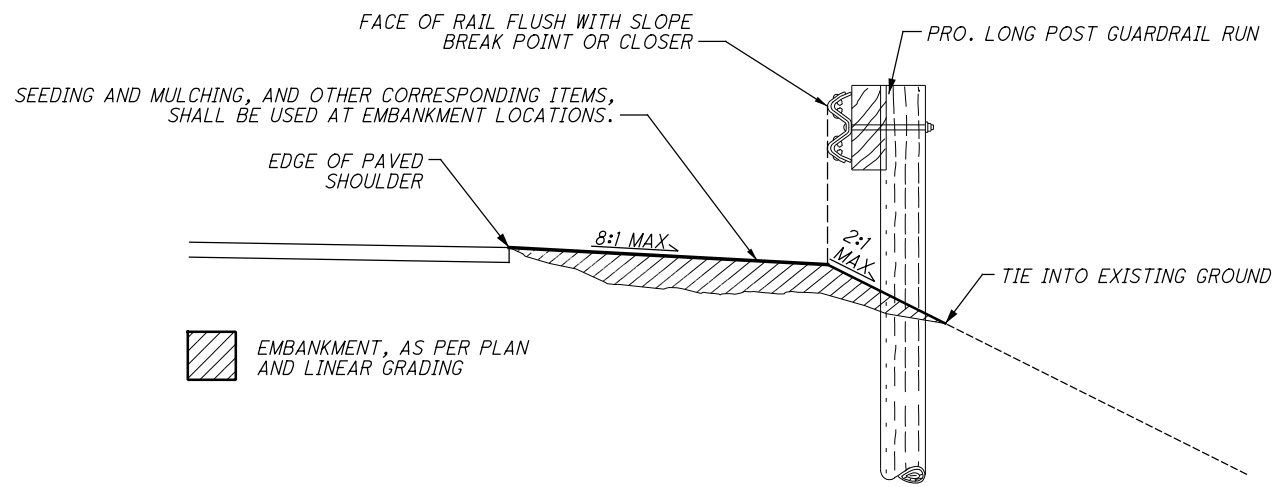

**GUARDRAIL DETAIL 2  
SECTION B-B**

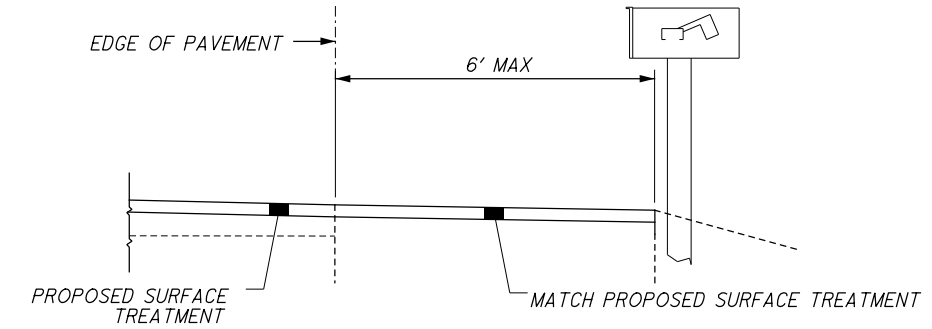

**MAILBOX APPROACH DETAIL**

FOR EXISTING PAVED MAILBOX APPROACHES ONLY  
SEE GENERAL NOTES FOR MORE INFORMATION  
REGARDING MAILBOX APPROACH TREATMENTS.  
FOR GRAVEL APPROACHES, USE ITEM 617.

I:\ProjectData\07824\_PIC-316-13.05\Design\Roadway\Sheets\GA\_001.dgn GA\_002 12/16/2019 2:48:13 PM rmcneill

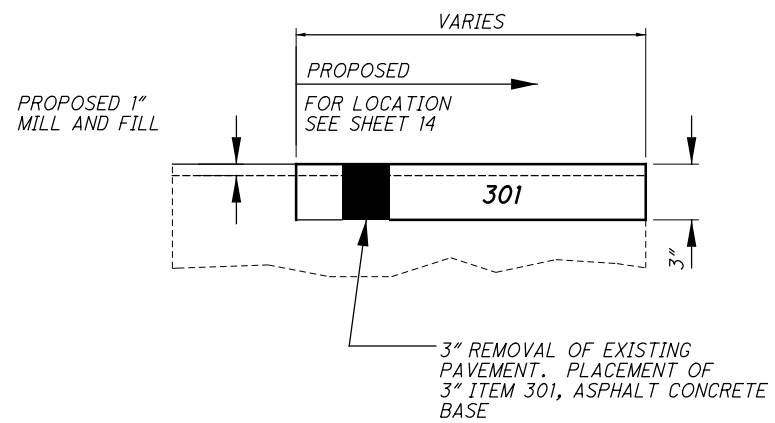

**PARTIAL DEPTH PAVEMENT REPAIR DETAIL, TYPE A**  
 SEE GENERAL NOTES FOR MORE INFORMATION REGARDING ITEM 251-PARTIAL DEPTH PAVEMENT REPAIR, (ASPHALT CONCRETE BASE) AS PER PLAN.

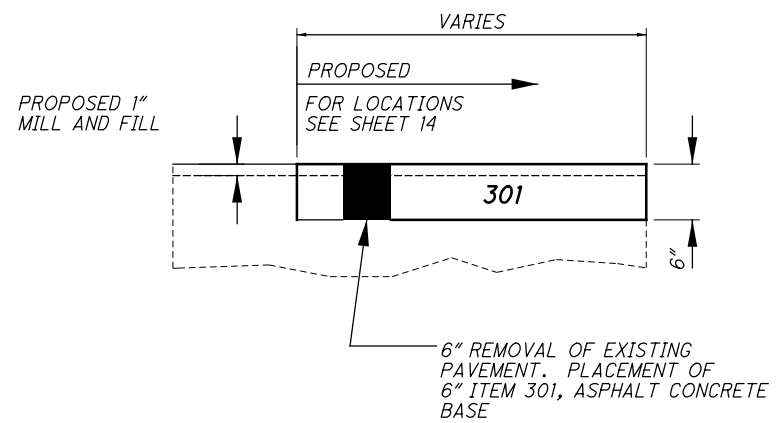

**PARTIAL DEPTH PAVEMENT REPAIR DETAIL, TYPE B**  
 SEE GENERAL NOTES FOR MORE INFORMATION REGARDING ITEM 251-PARTIAL DEPTH PAVEMENT REPAIR, (ASPHALT CONCRETE BASE) AS PER PLAN.

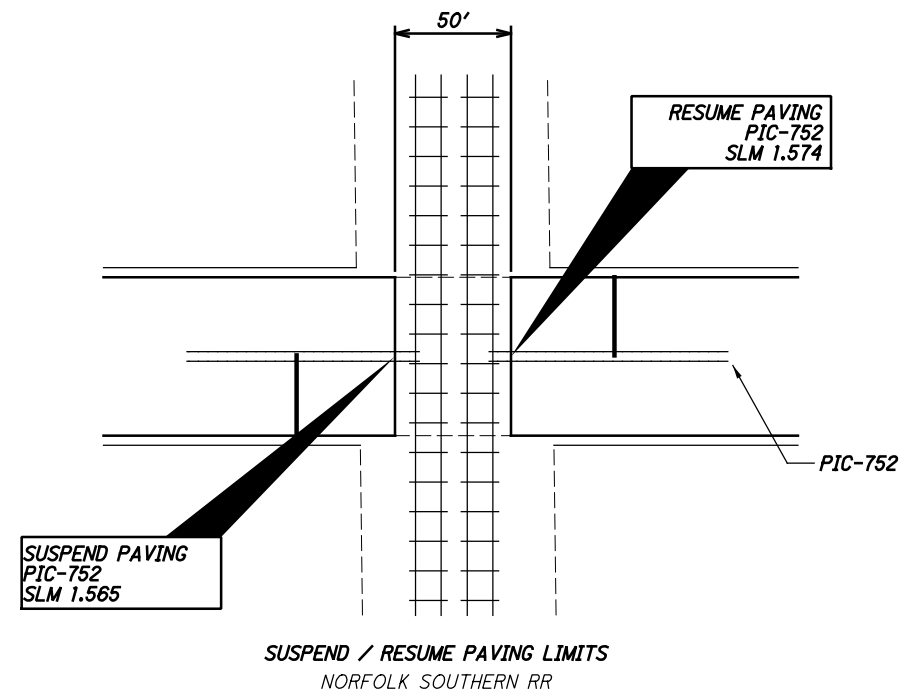

**TYPICAL DETAILS**

**PIC-SR 316 / 752-  
13.05 / 0.00**

I:\ProjectData\07824\_PIC-316-13.05\Design\Roadway\Sheets\GA\_001.dgn GA\_003 12/16/2019 2:48:14 PM rmcneill

**GENERAL:**

THE CONTRACTOR SHALL SUBMIT IN WRITING A SCHEDULE OF OPERATIONS TO THE ENGINEER (SEE 108.02) AND RECEIVE APPROVAL IN WRITING BEFORE WORK IS STARTED ON THIS PROJECT. ALL TRAFFIC CONTROL DEVICES SHALL BE FURNISHED, ERECTED, MAINTAINED, AND REMOVED BY THE CONTRACTOR IN ACCORDANCE WITH THE OHIO MANUAL OF UNIFORM TRAFFIC CONTROL DEVICES.

**NOTIFICATION OF CONSTRUCTION INITIATION:**

AT LEAST FOURTEEN DAYS PRIOR TO STARTING INITIAL CONSTRUCTION ACTIVITIES, THE CONTRACTOR SHALL ADVISE THE DISTRICT OFFICE OF COMMUNICATIONS VIA EMAIL AT d06.pio@dot.ohio.gov, THE DISTRICT WORK ZONE TRAFFIC MANAGER VIA EMAIL AT d06.mot@dot.ohio.gov AND THE CENTRAL OFFICE SPECIAL HAUL PERMITS SECTION BY FAX AT (614)728-4099 OF THE ANTICIPATED START DATE OF ANY CONSTRUCTION ACTIVITIES INCLUDING BUT NOT LIMITED TO THE PLACING OF WORK ZONE SIGNS. THE NOTIFICATION SHALL ALSO INCLUDE THE PROJECT NUMBER, PID, NAME AND PHONE NUMBER OF THE CONTRACTOR, A POINT OF CONTACT AND THE ANTICIPATED IMPACT ON TRAFFIC. THE CONTRACTOR WILL IMMEDIATELY INFORM THE DISTRICT OFFICE OF COMMUNICATIONS AND THE DISTRICT WORK ZONE TRAFFIC MANAGER OF ANY AND ALL DELAYS AND/OR CHANGES REGARDING THE CONSTRUCTION INITIATION DATE.

**CONTRACTORS EQUIPMENT - OPERATION AND STORAGE:**

THE CONTRACTOR'S EQUIPMENT SHALL BE OPERATED IN THE DIRECTION OF TRAFFIC WHERE PRACTICAL. EQUIPMENT SHALL HAVE AT LEAST ONE AMBER FLASHING LIGHT. WHEN PARKED ALONG THE HIGHWAY, THE EQUIPMENT SHALL BE LOCATED EITHER A MINIMUM OF THIRTY FEET FROM THE EDGE OF PAVEMENT OR SIX FEET BEHIND GUARDRAIL WITH A MINIMUM OF 125 FEET OF GUARDRAIL PRECEDING THE EQUIPMENT. ALL OTHER EQUIPMENT, INCLUDING PRIVATE VEHICLES, SHALL BE STORED AT AN APPROVED CONTRACTOR'S STORAGE AREA.

**CONTINGENCY QUANTITIES:**

THE CONTRACTOR SHALL NOT ORDER MATERIALS OR PERFORM WORK FOR ITEMS DESIGNATED BY PLAN NOTE TO BE USED "AS DIRECTED BY THE ENGINEER" UNLESS AUTHORIZED BY THE ENGINEER. THE ACTUAL WORK LOCATIONS AND QUANTITIES USED FOR SUCH ITEMS SHALL BE INCORPORATED INTO THE FINAL CHANGE ORDER GOVERNING COMPLETION OF THIS PROJECT.

**WORK LIMITS:**

THE WORK LIMITS SHOWN ON THESE PLANS ARE FOR PHYSICAL CONSTRUCTION ONLY. THE INSTALLATION AND OPERATION OF ALL TEMPORARY TRAFFIC CONTROL AND TEMPORARY TRAFFIC CONTROL DEVICES REQUIRED BY THESE PLANS SHALL BE PROVIDED BY THE CONTRACTOR WHETHER INSIDE OR OUTSIDE THESE WORK LIMITS.

**ALIGNMENT AND PROFILE:**

THE WORK PROPOSED BY THIS PROJECT IS FOR TREATMENT ON THE EXISTING PAVEMENT. THE ALIGNMENT OF THE EXISTING PAVEMENT WILL NOT BE CHANGED, AND THE PROFILE OF THE PROPOSED SURFACE WILL BE SIMILAR TO THAT OF THE EXISTING PAVEMENT.

**PART-WIDTH CONSTRUCTION:**

BECAUSE OF THE NECESSITY TO BUILD THIS PROJECT UNDER TRAFFIC AND TO CONSTRUCT THE FULL PAVEMENT WIDTH IN STAGES, EXERCISE CARE TO PREVENT THE CONSTRUCTION OF A BUTT JOINT IN THE BASE COURSES. LAP LONGITUDINAL JOINTS AS SHOWN ON STANDARD CONSTRUCTION DRAWING BP-3.1.

**DRAINAGE AT INTERSECTING STREETS:**

AT INTERSECTING STREETS WHERE THE DRAINAGE IS TOWARD OR INTO THE PROJECT, SPECIAL CARE SHALL BE TAKEN BY THE CONTRACTOR TO MAINTAIN PROPER GRADE ALONG THE EDGE OF PAVEMENT SO THAT WATER WILL NOT POND. AT INTERSECTING STREETS, WHERE THE EDGE OF PAVEMENT CONTINUES ACROSS THE STREET, CARE SHALL BE TAKEN TO FEATHER DOWN AND FORM A NEAT SEAM WITH THE PROPER GRADE.

**UTILITIES:**

NO UTILITY IMPACT IS ANTICIPATED DUE TO THE SCOPE OF WORK. APPROXIMATE LOCATIONS OF UNDERGROUND UTILITIES HAVE BEEN SHOWN ON THESE PLANS IN THE AREAS OF PROPOSED WORK. IT IS ODOT'S EXPECTATION THAT THERE WILL BE NO CONFLICTS WITH THESE UTILITIES. THE ODOT CONTRACTOR IS REQUIRED TO CONTACT OUPS A MINIMUM OF 48 HOURS EXCLUDING WEEKENDS AND HOLIDAYS TO PERMIT ALL UNDERGROUND UTILITIES AN OPPORTUNITY TO MARK THEIR LINES. IT IS ALSO THE ODOT CONTRACTOR'S RESPONSIBILITY TO CONTACT ALL NON-MEMBERS OF OUPS DIRECTLY A MINIMUM OF 48 HOURS' NOTICE EXCLUDING WEEKENDS AND HOLIDAYS TO PROVIDE THEM WITH THE SAME OPPORTUNITY. IT IS ALSO THE ODOT CONTRACTOR'S RESPONSIBILITY TO LOCATE ANY UNDERGROUND RAILROAD SIGNAL AND COMMUNICATION LINES BEFORE PERFORMING ANY WORK IN THE RAILROAD RIGHT OF WAY.

IT IS ODOT'S EXPECTATION THAT ALL GUARD RAIL POSTS WILL BE INSTALLED IN THE SAME LOCATIONS AND THERE WILL BE NO DISRUPTION TO UNDERGROUND UTILITIES. IF THERE IS A UTILITY MARKING WITHIN THE TOLERANCE ZONE OF A UTILITY LOCATE FROM THE PROPOSED GUARDRAIL PLACEMENT IT IS THE ODOT CONTRACTORS RESPONSIBILITY TO DIRECTLY CONTACT THE IMPACTED UTILITY AND WORK WITH THEM TO FIND A SOLUTION THAT DOES NOT CHANGE THE GUARDRAIL PLACEMENT OR DAMAGE THE EXISTING UTILITY. NO UTILITY RELOCATION WILL BE REIMBURSED NOR WILL DELAY CLAIMS BE PERMISSIBLE BASED ON LACK OF COORDINATION BETWEEN THE ODOT CONTRACTOR AND THE IMPACTED UTILITY.

OHIO 811: 1-800-362-2764  
NON-MEMBERS MUST BE CALLED DIRECTLY.

**DRIVEWAYS, SIDE ROADS, AND MAILBOX APPROACHES:**

QUANTITIES AND DETAILS HAVE BEEN PROVIDED FOR THE TREATMENT OF DRIVEWAYS, INTERSECTIONS, AND MAILBOX APPROACHES. THE CONTRACTOR SHALL EXPECT TO "PAVE BACK" ON ALL EXISTING SIDE ROADS AS LISTED AND DETAILED IN THE TYPICAL DETAIL SECTION OF THIS PLAN. ONLY EXISTING ASPHALT MAILBOXES SHALL RECEIVE PROPOSED ASPHALT TREATMENTS. QUANTITIES OF ITEM 617 - COMPACTED AGGREGATE HAS BEEN PROVIDED IN THE PLANS TO ACCOMMODATE FOR NON-ASPHALT APPROACHES.

**ENVIRONMENTAL:**

THE CONTRACTOR SHALL TAKE CARE TO AVOID IMPACTING ANY STREAMS, DITCHES, AND/OR WETLANDS.

THIS PROJECT IS LOCATED WITHIN THE ZONE A/AE FLOODWAY. THE CONTRACTOR WILL ENSURE THAT THE ROADWAY WORK MAINTAINS THE EXISTING/CURRENT ROADWAY ELEVATION.

**REMOVAL ITEMS:**

UNLESS OTHERWISE INSTRUCTED, GUARDRAIL, POSTS, ASPHALT, CONCRETE, AND MISCELLANEOUS HARDWARE DESIGNATED FOR REMOVAL BECOME PROPERTY OF THE CONTRACTOR AND SHALL BE DISPOSED OF. PAYMENT FOR THE ABOVE SHALL BE INCLUDED IN THE UNIT PRICE BID FOR THE REMOVED ITEM.

**ITEM 202 - GUARDRAIL REMOVED, AS PER PLAN:**

**ITEM 202 - ANCHOR ASSEMBLY REMOVED, TYPE A, AS PER PLAN:**

**ITEM 202 - BRIDGE TERMINAL ASSEMBLY REMOVED, AS PER PLAN:**

IN ADDITION TO THE REQUIREMENTS OF ITEM 202, REMOVAL OF SPECIFIED GUARDRAIL ITEMS SHALL INCLUDE BUT NOT BE LIMITED TO ANY ATTACHED POSTS, SIGNS AND DELINEATORS (NOT OTHERWISE SPECIFIED). THIS REMOVAL WILL INCLUDE ALL POSTS, ANCHORS AND HARDWARE UNDER GROUND.

THE CONTRACTOR SHALL REMOVE ALL CONCRETE FOUNDATIONS COMPLETELY AT ALL LOCATIONS.

EXISTING TYPE T ANCHOR ASSEMBLIES (NOT IDENTIFIED IN THE PLANS) ENCOUNTERED WITHIN REMOVAL LIMITS SHALL BE REMOVED UNDER THE QUANTITIES PROVIDED FOR ITEM 202 - GUARDRAIL REMOVED, AS PER PLAN, AND BE PAID FOR BY "FEET".

ALL HOLES AND VOIDS REMAINING AFTER REMOVAL OF GUARDRAIL POSTS AND FOUNDATIONS SHALL BE FILLED WITH GRANULAR MATERIAL CONFORMING TO CMS 203.02R. FILL MATERIAL CONTAINING SOD SHALL NOT BE USED. ALL FILL MATERIAL SHALL BE APPROVED BY THE ENGINEER. MATERIAL PLACED IN HOLES SHALL BE THOROUGHLY COMPACTED AND LEVELED OFF AS DIRECTED BY THE ENGINEER. PAYMENT FOR THE ABOVE SHALL BE INCLUDED IN THE UNIT PRICE BID FOR THE APPLICABLE GUARDRAIL REMOVAL ITEM.

NO HAZARD SHALL BE LEFT UNPROTECTED EXCEPT FOR THE ACTUAL TIME NECESSARY TO REMOVE THE EXISTING GUARDRAIL, PREPARE THE SITE, AND INSTALL NEW GUARDRAIL IN A CONTINUOUS OPERATION. GUARDRAIL DESIGNATED FOR REMOVAL SHALL BECOME PROPERTY OF THE CONTRACTOR AND SHALL BE DISPOSED OF.

**ITEM 203 - EMBANKMENT, AS PER PLAN:**

QUANTITIES FOR ITEM 203 - EMBANKMENT HAVE BEEN PROVIDED THROUGHOUT THIS PLAN TO BUILD UP FORE-SLOPES AND ENSURE PROPER GRADING FOR THE PROPOSED ANCHOR ASSEMBLIES AND LONG SPAN GUARDRAIL. THIS ITEM OF WORK INCLUDES ANY CLEARING AND GRUBBING NECESSARY TO PLACE THE EMBANKMENT AT THE LOCATIONS SPECIFIED OR DIRECTED. THE CONTRACTOR SHALL BE PREPARED TO USE EMBANKMENT AT THE LOCATIONS SPECIFIED IN THE PLANS AND ANY OTHER AREAS "AS DIRECTED BY THE ENGINEER". SEE TYPICAL DETAILS FOR SECTION VIEWS.

**CONNECTION BETWEEN EXISTING AND PROPOSED GUARDRAIL:**

WHEN IT IS NECESSARY TO SPLICE PROPOSED GUARDRAIL TO EXISTING GUARDRAIL, ONLY THE EXISTING GUARDRAIL SHALL BE CUT, DRILLED, OR PUNCHED. THE CONNECTION SHALL BE MADE USING A W-BEAM, BEAM SPLICE AS SHOWN IN AASHTO M 180-12, EXCEPT THE BEAM WASHERS ARE NOT TO BE USED. PAYMENT SHALL BE INCLUDED IN THE CONTRACT PRICE FOR THE RESPECTIVE GUARDRAIL ITEMS.

**CURVED RAIL ELEMENTS:**

ALL RADII OF CURVED RAIL ARE ESTIMATED AND ACTUAL RADII OF PROPOSED RAIL SHALL BE DETERMINED IN THE FIELD BY THE CONTRACTOR PRIOR TO ORDERING. LENGTH OF CURVED RAIL ELEMENTS, WHERE CALLED FOR IN A RUN, SHALL BE INCLUDED IN THE TOTAL LENGTH OF RUN SHOWN IN THE GUARDRAIL COLUMN AND THE CURVED RAIL ELEMENT TOTAL ARE INCLUDED WITH THE GUARDRAIL TOTALS ON THE GENERAL SUMMARY SHEET. LOCATIONS OF ANY CURVED RAIL ARE IDENTIFIED IN THE PLAN SHEETS.

CALCULATED  
RAM  
CHECKED  
XXX

GENERAL NOTES

PIC-SR 316 / 752 -  
13.05 / 0.00

7  
36

**ITEM 606 - GUARDRAIL, MISC.: ALTERNATIVE GUARDRAIL PLACEMENT:**  
 THIS ITEM SHALL BE USED WHEN THE CONTRACTOR IS REQUIRED TO USE AN ALTERNATE METHOD TO SET POSTS TO PREVENT DAMAGE TO AN UNDERGROUND OBSTACLE, SUCH AS A UTILITY. THE USE OF THIS ITEM WILL BE AS DEEMED NECESSARY BY THE ENGINEER. THIS ITEM SHALL INCLUDE ALL LABOR, EQUIPMENT, AND MATERIAL NEEDED TO SET AND BACKFILL POSTS WHILE MEETING THE REQUIREMENTS OF THE APPLICABLE GUARDRAIL ITEM BEING PERFORMED. APPLICABLE GUARDRAIL ITEMS INCLUDE BUT ARE NOT LIMITED TO SETTING POSTS (AND SLEEVES) FOR TYPE 5, TYPE MGS, ANCHOR ASSEMBLIES, AND BRIDGE TERMINAL ASSEMBLIES. PAYMENT SHALL BE AT THE UNIT BID PRICE OF EACH AND SHALL BE PAID FOR IN ADDITION TO THE APPLICABLE GUARDRAIL PLACEMENT ITEM LISTED ABOVE.

LOC	COUNTY	ROUTE	BEG SLM	END SLM	QUANTITY	UNIT
1	PIC	752	0.00	8.43	50	FT
TOTAL					50	FT

THE FOLLOWING ESTIMATED QUANTITIES HAVE BEEN PROVIDED:  
 ITEM 606 - GUARDRAIL, MISC.: ALTERNATIVE GUARDRAIL PLACEMENT: = 50 FT

**ITEM 606 - ITEM 606 - ANCHOR ASSEMBLY, (MGS) TYPE E, AS PER PLAN:**

THIS ITEM SHALL CONSIST OF FURNISHING AND INSTALLING ANY OF THE GUARDRAIL END TERMINALS FOR TYPE MGS GUARDRAIL AS LISTED ON ROADWAY ENGINEERING'S WEB PAGE UNDER ROADSIDE SAFETY DEVICES FOR APPROVED GUARDRAIL END TREATMENTS. INSTALLATION SHALL BE AT THE LOCATIONS SPECIFIED IN THE PLANS, IN ACCORDANCE WITH THE MANUFACTURER'S SPECIFICATIONS.

**WHEN THE FACE OF THE ADJACENT (ATTACHED) GUARDRAIL IS LESS THAN 4' OFFSET FROM THE PROPOSED EDGE LINE, THE PROPOSED TYPE E ANCHOR ASSEMBLY SHALL BE INSTALLED USING A 25:1 FLARE RATE (24" OFFSET DESIGN) AS DETAILED IN THE SHOP DRAWINGS AND AS DIRECTED BY THE ENGINEER.**

THE FACE OF THE TYPE E IMPACT HEAD SHALL BE COVERED WITH A SHEET OF TYPE G REFLECTIVE SHEETING, PER CMS 730.19.

REFER TO THE MANUFACTURER'S INSTRUCTIONS REGARDING THE INSTALLATION OF, AND THE GRADING AROUND THE FOUNDATION TUBES AND GROUND STRUT. THE TOP OF ANY FOUNDATION TUBE SHOULD BE LESS THAN 4 INCHES ABOVE THE GROUND. THE PLACEMENT OF THE FOUNDATION TUBES SHOULD BE AN APPROPRIATE DEPTH BELOW THE LEVEL LINE IN ORDER TO MAINTAIN THE FINISHED GUARDRAIL HEIGHT OF 31 INCHES FROM THE EDGE OF THE SHOULDER.

ON-SITE GRADING IS REQUIRED IF THE TOP OF THE FOUNDATION TUBES OR TOP OF THE GROUND STRUT DOES PROJECT MORE THAN 4 INCHES ABOVE THE GROUND LINE.

**THE PAYMENT LIMIT (LENGTH) FOR THE PROPOSED ANCHOR ASSEMBLY, (MGS) TYPE E, AS PER PLAN SHALL BE 53'-1/2" (TO THE STANDARD MGS CONNECTION) AS DETAILED BELOW.**

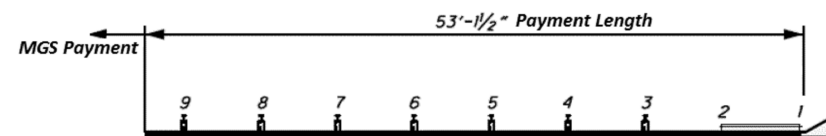

PAYMENT FOR THE ABOVE WORK SHALL BE MADE AT THE UNIT PRICE BID FOR ITEM 606, ANCHOR ASSEMBLY, MGS TYPE E, EACH, AND SHALL INCLUDE ALL LABOR, TOOLS, EQUIPMENT AND MATERIALS NECESSARY TO CONSTRUCT A COMPLETE AND FUNCTIONAL ANCHOR ASSEMBLY SYSTEM, INCLUDING ALL RELATED TRANSITIONS, REFLECTIVE SHEETING, HARDWARE, GRADING, EMBANKMENT AND EXCAVATION NOT SEPARATELY SPECIFIED, AS REQUIRED BY THE MANUFACTURER.

**ITEM 606 - BRIDGE TERMINAL ASSEMBLY, TYPE 4, AS PER PLAN:**  
 BRIDGE TERMINAL ASSEMBLY, TYPE 4, AS PER PLAN SHALL BE CONSTRUCTED AS PER THE GUARDRAIL DETAILS (PLAN INSERT) ON SHEETS 19/36. PAYMENT FOR THIS ITEM SHALL BE MADE AT THE UNIT PRICE BID OF EACH AND SHALL INCLUDE ALL LABOR, TOOLS, EQUIPMENT, MATERIALS, AND ALL TYPE 5 GUARDRAIL COMPONENTS NECESSARY TO CONSTRUCT A COMPLETE AND FUNCTIONAL BRIDGE TERMINAL ASSEMBLY, TYPE 4.

**ITEM 623 - MONUMENT BOX ADJUSTED TO GRADE:**  
 THIS ITEM OF WORK WILL PROVIDE ALL MATERIAL, LABOR, EQUIPMENT, AND HARDWARE NECESSARY TO ADJUST TO GRADE THE EXISTING MONUMENT BOX TO 1/4 INCH BELOW THE PROPOSED ASPHALT ELEVATION.

THE FOLLOWING QUANTITY HAS BEEN PROVIDED AND THE TOTAL HAS BEEN CARRIED TO THE GENERAL SUMMARY:  
 ITEM 623 - MONUMENT BOX ADJUSTED TO GRADE: = 4 EACH

**ITEM 690 - MAILBOX REMOVED AND RESET:**  
 THIS ITEM IS A CONTINGENCY QUANTITY TO BE USED AS DIRECTED BY THE PROJECT ENGINEER FOR MAILBOXES ENCRACHING INTO THE PROPOSED ASPHALT SHOULDER TREATMENT AND/OR GUARDRAIL REPLACEMENT. THE CONTRACTOR SHALL PROVIDE ALL MATERIAL, LABOR, EQUIPMENT, AND HARDWARE NECESSARY TO REMOVE AND RESET EXISTING MAILBOXES. IT IS EXPECTED THAT THE CONTRACTOR WILL PROVIDE A NEW SUPPORT.

WOOD POSTS SHALL BE NOMINAL 4 INCHES BY 4 INCHES SQUARE OR 4.5 INCHES DIAMETER ROUND, AND CONFORM TO 710.14. STEEL POSTS SHALL BE NOMINAL PIPE SIZE 2 INCHES I.D., AND CONFORM TO AASHTO M 181. ALL HARDWARE INCLUDING BUT NOT LIMITED TO PLATES, SCREWS, BOLTS, AND ETC. SHALL BE COMMERCIAL-GRADE GALVANIZED STEEL. POSTS SHALL BE SET PER THE FIRST PARAGRAPH OF 606.03, AND SHALL IN NO INSTANCE BE ENCASED IN CONCRETE. SUPPORT HARDWARE SHALL ACCOMMODATE EITHER A SINGLE OR A DOUBLE MAILBOX INSTALLATION, AND NO MORE THAN TWO BOXES MAY BE MOUNTED ON A SINGLE POST.

THE MAILBOX SHALL BE SECURELY AND NEATLY ATTACHED BY THE CONTRACTOR TO THE NEW SUPPORT. THE CONTRACTOR SHALL FURNISH ALL NECESSARY ATTACHMENT HARDWARE (NUTS, BOLTS, PLATES, SPACERS, AND WASHERS) AS NECESSARY TO ACCOMMODATE THE COMPLETE INSTALLATION.

IN THE ABSENCE OF A NEW BOX SUPPLIED BY THE OWNER, THE CONTRACTOR SHALL SALVAGE THE EXISTING BOX AND PLACE IT ON THE NEW SUPPORT. DUE CARE SHALL BE EXERCISED IN SUCH AN OPERATION, AND THE CONTRACTOR SHALL BE RESPONSIBLE FOR REPAIRING OR REPLACING ANY BOX DAMAGED BY IMPROPER HANDLING ON HIS PART, AS JUDGED AND DIRECTED BY THE ENGINEER.

THIS ITEM IS NOT INTENDED FOR MAILBOX OR MAILBOX POSTS WHICH BECOME DAMAGED BY THE CONTRACTOR. GREAT CARE SHALL BE TAKEN TO PREVENT DAMAGE TO ANY OF THE EXISTING MAILBOXES OR MAILBOX POSTS DURING THE PAVING OPERATIONS. ANY MAILBOX OR MAILBOX POST WHICH BECOMES DAMAGED BY THE CONTRACTOR'S PAVING OPERATIONS SHALL BE REMOVED AND REPLACED AT THE CONTRACTOR'S EXPENSE.

THE FOLLOWING QUANTITY HAS BEEN PROVIDED AND THE TOTAL HAS BEEN CARRIED TO THE GENERAL SUMMARY:  
 ITEM 690 - MAILBOX REMOVED AND RESET = 2 EACH

**GRADING AND EROSION CONTROL:**  
 AREAS DISTURBED BY GUARDRAIL ACTIVITIES AND AREAS WHERE EMBANKMENT HAVE BEEN PLACED SHALL BE REPAIRED WITH THE FOLLOWING QUANTITIES, AS DIRECTED BY THE ENGINEER. THE FOLLOWING ESTIMATED QUANTITIES HAVE BEEN PROVIDED:

ITEM	QUANTITY	UNIT	DESCRIPTION
659	222	CY YD	TOPSOIL
659	1950	SQ YD	SEEDING AND MULCHING
659	98	SQ YD	REPAIR SEEDING AND MULCHING
659	98	SQ YD	INTER-SEEDING
659	0.26	TON	COMMERCIAL FERTILIZER
659	0.40	ACRE	LIME
659	11	M.GAL	WATER

**MANHOLES AND OTHER CASTING STRUCTURES:**  
 THE CASTING TOPS OF MANHOLES, VALVE BOXES, AND OTHER STRUCTURES OWNED BY PUBLIC SERVICE CORPORATIONS MAY BE ADJUSTED TO GRADE BY THEIR RESPECTIVE OWNERS OR GIVE AUTHORIZATION TO ODOT TO ADJUST AS PART OF THIS CONTRACT. THIS WORK NEEDS TO BE COMPLETED PRIOR TO THE CONSTRUCTION OF THE SURFACE COURSE. THE CONTRACTOR SHALL NOTIFY SUCH PUBLIC SERVICE CORPORATIONS A MINIMUM OF 7 CALENDAR DAYS IN ADVANCE OF WORK OPERATIONS SO THAT WORK MAY BE PROPERLY SCHEDULED.

THE CASTING TOPS OF MANHOLES, VALVE BOXES, AND OTHER STRUCTURES REQUIRING ADJUSTMENT THAT ARE OWNED BY PRIVATE UTILITIES NEED TO BE ADJUSTED TO GRADE BY THEIR RESPECTIVE OWNERS. THE ODOT CONTRACTOR SHALL NOTIFY THE PRIVATE OWNER A MINIMUM OF 7 CALENDAR DAYS IN ADVANCE OF WORK OPERATIONS SO THE WORK MAY BE PROPERLY SCHEDULED.

IF ADJUSTMENTS HAVE NOT BEEN COMPLETED 14 CALENDAR DAYS AFTER NOTIFICATION, THE ODOT CONTRACTOR WILL NOTIFY THE ODOT PROJECT ENGINEER AND PROVIDE SPECIFIC STATION LOCATIONS AND OWNER INFORMATION. THE ODOT PROJECT ENGINEER WILL WORK WITH THE DISTRICT UTILITY COORDINATOR TO ISSUE AND OBSTRUCTION REMOVAL NOTICE WITHIN 5 DAYS OF RECEIPT WHICH WILL INFORM THE PRIVATE UTILITY TO ADJUST THE STRUCTURES AS NECESSARY OR ODOT WILL AUTHORIZE THE ODOT CONTRACTOR TO ADJUST AS NEEDED AND BILL THE OWNER OF THE FACILITY FOR THE ADJUSTMENT TO THE STRUCTURE.

SHOULD THE CONTRACTOR FAIL TO NOTIFY PUBLIC SERVICE CORPORATIONS OR PRIVATE UTILITIES OF EXISTING MANHOLES, VALVE BOXES, AND OTHER STRUCTURES THAT REQUIRE ADJUSTMENTS TO GRADE, AND COVER THESE WITH THE PROPOSED ASPHALT TREATMENT, THE CONTRACTOR WILL BE REQUIRED TO UNCOVER THE MANHOLES, VALVE BOXES, AND OTHER STRUCTURES AT THEIR OWN EXPENSE SO THAT THE NECESSARY ADJUSTMENTS CAN BE MADE. THE METHOD OF REMOVAL AND REPAIR OF THE ASPHALT SHALL MEET ALL REQUIREMENTS OF THE ODOT ENGINEER AND SHALL BE AT THE CONTRACTORS EXPENSE.

THESE ITEMS PROVIDED BELOW ARE CONTINGENCY QUANTITIES TO BE USED AS DIRECTED BY THE PROJECT ENGINEER AT VARIOUS LOCATIONS. THESE ITEMS SHALL INCLUDE THE COST OF ALL MATERIAL, LABOR, EQUIPMENT, AND HARDWARE NECESSARY TO ADJUST CASTINGS TO GRADE TO THE PROPOSED ASPHALT ELEVATION AS DIRECTED.

THE FOLLOWING QUANTITIES HAS BEEN PROVIDED AND THE TOTAL HAS BEEN CARRIED TO THE GENERAL SUMMARY.

ITEM 611 - MANHOLE ADJUSTED TO GRADE = 4 EACH  
 ITEM 638 - VALVE BOX ADJUSTED TO GRADE = 4 EACH

I:\ProjectData\07824\_PIC-316-13.05\Design\Roadway\Sheets\GN\_001.dgn GN\_002 12/16/2019 2:48:41PM rmcneill

CALCULATED  
RAM  
CHECKED  
XXX

GENERAL NOTES

PIC-SR 316 / 752 -  
13.05 / 0.00



**REVIEW OF DRAINAGE FACILITIES**

BEFORE ANY WORK IS STARTED ON THE PROJECT AND AGAIN BEFORE FINAL ACCEPTANCE BY THE STATE, REPRESENTATIVES OF THE STATE AND THE CONTRACTOR, ALONG WITH LOCAL REPRESENTATIVES, SHALL MAKE AN INSPECTION OF ALL EXISTING SEWERS WHICH ARE TO REMAIN IN SERVICE AND WHICH MAY BE AFFECTED BY THE WORK. THE CONDITION OF THE EXISTING CONDUITS AND THEIR APPURTENANCE SHALL BE DETERMINED FROM FIELD OBSERVATIONS. RECORDS OF THE INSPECTION SHALL BE KEPT IN WRITING ALONG WITH PHOTOS BY THE STATE.

ALL NEW CONDUITS, INLETS, CATCH BASINS, AND MANHOLES CONSTRUCTED AS A PART OF THE PROJECT SHALL BE FREE OF ALL FOREIGN MATTER AND IN A CLEAN CONDITION BEFORE THE PROJECT WILL BE ACCEPTED BY THE STATE.

ALL EXISTING SEWERS INSPECTED INITIALLY BY THE ABOVE MENTIONED PARTIES SHALL BE MAINTAINED AND LEFT IN A CONDITION REASONABLY COMPARABLE TO THAT DETERMINED BY THE ORIGINAL INSPECTION. ANY CHANGE IN THE CONDITION RESULTING FROM THE CONTRACTOR'S OPERATIONS SHALL BE CORRECTED BY THE CONTRACTOR TO THE SATISFACTION OF THE ENGINEER.

PAYMENT FOR ALL OPERATIONS DESCRIBED ABOVE SHALL BE INCLUDED IN THE CONTRACT PRICE FOR THE PERTINENT 611 CONDUIT ITEMS.

**FIRE HYDRANTS:**

THE CONTRACTOR SHALL BE RESPONSIBLE FOR OBTAINING ANY PERMITS AND FEES THAT ARE REQUIRED FOR THE USE OF ANY FIRE HYDRANTS. A SIAMESE VALVE IS TO BE USED ON THE HYDRANT OUTLET IF A HOSE IS TO BE LEFT CONNECTED AND UNATTENDED.

**ITEM 251 - PARTIAL DEPTH PAVEMENT REPAIR (ASPHALT CONCRETE BASE), TYPE A, AS PER PLAN:**

ALL AREAS TO BE REPAIRED SHALL BE LOCATED BY THE ENGINEER AND THE WORK PERFORMED PRIOR TO RESURFACING. REPAIR AREAS SHALL CONSIST OF REMOVING 3" OF PAVEMENT AND PLACING 3" ITEM 301 - ASPHALT CONCRETE BASE, PG64-22. PARTIAL DEPTH PAVEMENT REPAIR SHALL BE STARTED AND COMPLETED IN THE SAME WORKING DAY.

**ITEM 251 - PARTIAL DEPTH PAVEMENT REPAIR (ASPHALT CONCRETE BASE), TYPE B, AS PER PLAN:**

ALL AREAS TO BE REPAIRED SHALL BE LOCATED BY THE ENGINEER AND THE WORK PERFORMED PRIOR TO RESURFACING. REPAIR AREAS SHALL CONSIST OF REMOVING 6" OF PAVEMENT AND PLACING 6" OF ITEM 301 - ASPHALT CONCRETE BASE, PG64-22. PARTIAL DEPTH PAVEMENT REPAIR SHALL BE STARTED AND COMPLETED IN THE SAME WORKING DAY.

**ITEM 254 AND ITEM 897- PAVEMENT PLANING, ASPHALT CONCRETE**

THE CONTRACTOR SHALL BE TOTALLY RESPONSIBLE FOR ANY AND ALL DAMAGE TO THE CONTRACTORS EQUIPMENT THAT MAY RESULT FROM THE PLANING OPERATION, INCLUDING DAMAGE CAUSED BY CASTINGS AND LOOP DETECTORS. THE DEPTH OF PLANING CLOSE TO THE CASTINGS SHALL BE AS DIRECTED; TO ACHIEVE A SMOOTH RIDING FINISHED PAVEMENT. GREAT CARE SHALL BE TAKEN TO PREVENT THE REMOVAL OF THE EXISTING PAVEMENT CROSS SLOPE (CROWN) DURING THE PLANING OPERATIONS.

THE CONTRACTOR SHALL LIMIT THE PLANING OPERATION TO ONE LANE AT A TIME AS TO ENSURE THAT THE PROPOSED SURFACE COURSE IS BUTTING UP TO EITHER PROPOSED OR EXISTING ASPHALT.

PLANED PAVEMENT SHALL NOT BE EXPOSED TO TRAFFIC FOR MORE THAN 7 CALENDAR DAYS ON SECTIONS OF THE ROADWAY RECEIVING ITEM 254 PAVEMENT PLANING, AND 14 CALENDAR DAYS ON SECTIONS OF THE ROADWAY RECEIVING ITEM 897 PAVEMENT PLANING. SEE TYPICAL SECTIONS FOR DETAILS.

IN ORDER TO MEET THE DROP OFF REQUIREMENTS OF SCD MT-101.90, THE 3.00" MILL & FILL SECTIONS SHALL RECEIVE ONE LIFT OF THE PROPOSED ASPHALT SURFACE COURSE IMMEDIATELY FOLLOWING THE PLANING OPERATION.

**ITEM 442 - ASPHALT CONCRETE SURFACE COURSE, 12.5MM, TYPE A, (446), AS PER PLAN:**

ITEM 442 - ASPHALT CONCRETE SURFACE COURSE, 12.5MM, TYPE A, (446), AS PER PLAN MIX SHALL REQUIRE A PG76-22M BINDER.

SEE TYPICAL SECTIONS FOR LIMITING SECTIONS.

**ITEM 617 - WATER:**

THIS ITEM IS A CONTINGENCY QUANTITY AND SHALL BE USED WHERE AND AS DIRECTED BY THE ENGINEER.

THE FOLLOWING QUANTITY HAS BEEN PROVIDED AND THE TOTAL HAS BEEN CARRIED TO THE GENERAL SUMMARY.

ITEM 617 - WATER = 2 MGAL

**ITEM 897 - PATCHING PLANED SURFACE:**

THE FOLLOWING CONTINGENCY QUANTITY HAS BEEN PROVIDED TO BE USED AS DIRECTED BY THE ENGINEER FOR AREAS NEEDING REPAIR FOLLOWING THE FINE PLANING OPERATION.

LOC	COUNTY	ROUTE	QUANTITY
1	PIC	752	1000 SY
		TOTAL	1000 SY

THE FOLLOWING ESTIMATED QUANTITIES HAVE BEEN PROVIDED:  
ITEM 897 - PATCHING PLANED SURFACE = 1000 SY

**PROPOSED NO PASSING ZONES:**

THE PROPER PLACEMENT OF THE PASSING AND NO PASSING ZONES AS SHOWN ON PLAN SHEETS 25/30 THROUGH 29/30 SHALL BE CONFIRMED BY THE CONTRACTOR AND PLACED BY USING THE CONTROL POINTS SHOWN ON THE PLAN SHEETS FOR THE FOLLOWING LOCATIONS:

LOC	COUNTY	ROUTE	BEG SLM	END SLM
1	PIC	752	0.00	8.43

SLM'S ON THE PASSING ZONE SHEETS COULD BE DIFFERENT THAN THE SLM'S SHOWN ON THE PAVING PLAN. ALL START AND STOP SIM LOCATIONS SHALL BE WITHIN 0.005 MILES OF THE LOCATIONS SHOWN ON THE PLAN SHEETS LISTED ABOVE. A LETTER OF VERIFICATION OF ALL PASSING AND NO PASSING ZONES SHALL BE SUBMITTED TO THE PROJECT ENGINEER FOR PLACEMENT IN THE PROJECT RECORDS. ANY IMPROPERLY PLACED PASSING OR NO PASSING ZONES SHALL BE IMMEDIATELY CORRECTED.

**ITEM 644 - PAVEMENT MARKING:**

WITH THE EXCEPTION OF THE PROPOSED PASSING ZONES, IT IS THE INTENT OF THE PROPOSED PAVEMENT MARKINGS TO BE THE SAME AS EXISTING. ANY DEVIATION FROM EXISTING WILL BE IDENTIFIED WITHIN THIS PLAN. IT IS THE CONTRACTOR'S RESPONSIBILITY TO VERIFY THE LOCATION, SIZE AND SHAPE OF THESE EXISTING PAVEMENT MARKINGS BEFORE THE SURFACE PREP OBLITERATES THEM. ANY PAVEMENT MARKING WHICH IS PLACED AT THE WRONG LOCATION SHALL BE REMOVED AND REPLACED AT THE CONTRACTORS EXPENSE.:

LOC	COUNTY	ROUTE	EDGE	LANE	CENTER
			LINE	LINE	LINE
			WIDTH	WIDTH	WIDTH
1	PIC	752	6"	6"	4"

**PAVING AT RAILROAD CROSSINGS:**

WORK THE CROWN OUT OF THE PROPOSED PAVEMENT ON EACH SIDE OF THE RAILROAD CROSSING, BEGINNING 50 FEET (15 METERS) FROM THE NEAREST RAIL, BY RAISING THE EDGES OF THE NEW PAVEMENT TO MEET THE PLATFORM ELEVATION.

WHEN PAVING UNDER A RAILROAD BRIDGE, EXTRA CARE SHALL BE TAKEN TO MAINTAIN EXISTING VERTICAL CLEARANCE.

**ITEM 623 - CONSTRUCTION LAYOUT STAKES AND SURVEYING, AS PER PLAN:**

THIS ITEM SHALL CONSIST OF STATIONING USING 3 FT LATH STAKES. THE STAKES SHALL BE SPACED AT 200 FT INTERVALS AND SHALL EXTEND THROUGHOUT THE LENGTH OF EACH PROJECT LOCATION AND THROUGHOUT THE LENGTH OF ANY RAMPS.

PLACEMENT OF THE STAKES SHALL BE AS DIRECTED BY THE ENGINEER. THE CONTRACTOR IS RESPONSIBLE FOR REPLACING ANY DAMAGED OR MISSING STAKES.

THIS ITEM SHALL ALSO BE USED IN THE EVENT THAT THE EXISTING RAILROAD RIGHT OF WAY NEEDS TO BE ESTABLISHED.

CONSTRUCTION LAYOUT STAKES, AS PER PLAN WILL BE PAID FOR AT THE CONTRACT LUMP SUM BID, WHICH SHALL BE FULL COMPENSATION FOR ALL SERVICES, MATERIALS, LABOR, EQUIPMENT, TOOLS, AND INCIDENTALS, INCLUDING THE REMOVAL, NECESSARY TO COMPLETE THIS ITEM.

I:\ProjectData\07824\_PIC-316-13.05\Design\Roadway\Sheets\GN\_001.dgn GN\_003 12/16/2019 2:49:07 PM rmcneill

CALCULATED  
RAM  
CHECKED  
XXX

GENERAL NOTES

PIC-SR 316 / 752 -  
13.05 / 0.00

**GENERAL:**

ALL TRAFFIC CONTROL DEVICES SHALL BE FURNISHED, ERECTED, MAINTAINED, AND REMOVED BY THE CONTRACTOR IN ACCORDANCE WITH THE OHIO MANUAL OF UNIFORM TRAFFIC CONTROL DEVICES (CURRENT EDITION). COPIES ARE AVAILABLE FROM:

THE OHIO DEPARTMENT OF TRANSPORTATION  
BUREAU OF TRAFFIC,  
1980 WEST BROAD STREET  
COLUMBUS, OHIO 43223.

LENGTH AND DURATION OF LANE CLOSURES AND RESTRICTIONS SHALL BE AT THE APPROVAL OF THE ENGINEER. IT IS THE INTENT TO MINIMIZE THE IMPACT TO THE TRAVELING PUBLIC. LANE CLOSURES OR RESTRICTIONS OVER SEGMENTS OF THE PROJECT IN WHICH NO WORK IS ANTICIPATED WITHIN A REASONABLE TIME FRAME, AS DETERMINED BY THE ENGINEER, SHALL NOT BE PERMITTED. THE LEVEL OF UTILIZATION OF MAINTENANCE OF TRAFFIC DEVICES SHALL BE COMMENSURATE WITH THE WORK IN PROGRESS.

ALL WORK AND TRAFFIC CONTROL DEVICES SHALL BE IN ACCORDANCE WITH CMS 614 AND OTHER APPLICABLE PORTIONS OF THE SPECIFICATIONS, AS WELL AS THE OHIO MANUAL OF UNIFORM TRAFFIC CONTROL DEVICES.

ALL PERMANENT TRAFFIC CONTROLS NOT IN CONFLICT WITH THE TEMPORARY TRAFFIC CONTROLS SHALL BE MAINTAINED THROUGHOUT THIS PROJECT BY THE CONTRACTOR. PERMANENT TRAFFIC CONTROLS MAY BE TEMPORARILY RELOCATED BY THE ENGINEER. THE CONTRACTOR SHALL ASSUME ALL LIABILITY FOR MISSING, DAMAGED, AND PROPERLY PLACED SIGNS.

PAYMENT FOR ALL LABOR, EQUIPMENT AND MATERIALS SHALL BE INCLUDED IN THE LUMP SUM CONTRACT PRICE FOR ITEM 614, MAINTAINING TRAFFIC, UNLESS SEPARATELY ITEMIZED IN THE PLAN.

**WORK SITE LIGHTING**

FLOODLIGHTING OF THE WORK SITE FOR OPERATIONS CONDUCTED DURING NIGHTTIME PERIODS SHALL BE ACCOMPLISHED SO THAT THE LIGHTS DO NOT CAUSE GLARE TO THE DRIVERS ON THE ROADWAY. TO ENSURE THE ADEQUACY OF THE FLOODLIGHT PLACEMENT, THE CONTRACTOR, AND THE ENGINEER SHALL DRIVE THROUGH THE WORK SITE EACH NIGHT WHEN THE LIGHTING IS IN PLACE AND OPERATIVE PRIOR TO COMMENCING ANY WORK. IF GLARE IS DETECTED, THE LIGHT PLACEMENT AND SHIELDING SHALL BE ADJUSTED TO THE SATISFACTION OF THE ENGINEER BEFORE WORK PROCEEDS. PAYMENT FOR ALL LABOR, EQUIPMENT, AND MATERIALS SHALL BE INCLUDED IN THE LUMP SUM CONTRACT PRICE FOR ITEM 614, MAINTAINING TRAFFIC.

**ITEM 614 - MAINTAINING TRAFFIC ON TWO LANE HIGHWAYS:**

TRAFFIC SHALL BE MAINTAINED ON TWO LANE HIGHWAYS AT ALL TIMES BY USE OF THE EXISTING AND COMPLETED PAVEMENT. WORK ZONES SHALL BE LIMITED IN LENGTH TO THE AMOUNT OF WORK THAT CAN BE PERFORMED THAT DAY. WORK ZONES SHALL BE IN ACCORDANCE WITH THE OHIO MANUAL OF UNIFORM TRAFFIC CONTROL DEVICES. TRAFFIC SHALL BE MAINTAINED BY FLAGGER FOR CLOSING 1 LANE OF A 2 LANE HIGHWAY FOR PAVING OPERATION AS PER STANDARD DRAWING MT-97.12.

**LANES OPEN DURING HOLIDAYS:**

NO WORK SHALL BE PERFORMED AND THE SAME NUMBER OF LANES AS WERE AVAILABLE AT THE START OF THE PROJECT SHALL BE OPEN TO TRAFFIC DURING THE FOLLOWING DESIGNATED HOLIDAYS OR EVENTS:

HOLIDAYS

CHRISTMAS                   FOURTH OF JULY  
NEW YEARS                 LABOR DAY  
MEMORIAL DAY             THANKSGIVING

THE PERIOD OF TIME THAT THE LANES ARE TO BE OPEN DEPENDS ON THE DAY OF THE WEEK ON WHICH THE HOLIDAY FALLS. THE FOLLOWING SCHEDULE SHALL BE USED TO DETERMINE THIS PERIOD:

DAY OF HOLIDAY	TIME ALL LANES MUST BE OPEN TO TRAFFIC
SUNDAY	12:00 NOON FRIDAY THROUGH 6:00 AM MONDAY
MONDAY	12:00 NOON FRIDAY THROUGH 6:00 AM TUESDAY
TUESDAY	12:00 NOON MONDAY THROUGH 6:00 AM WEDNESDAY
WEDNESDAY	12:00 NOON TUESDAY THROUGH 6:00 AM THURSDAY
THURSDAY	12:00 NOON WEDNESDAY THROUGH 6:00 AM FRIDAY
THANKSGIVING	5:00 AM WEDNESDAY THROUGH 6:00 AM MONDAY
FRIDAY	12:00 NOON THURSDAY THROUGH 6:00 AM MONDAY
SATURDAY	12:00 NOON FRIDAY THROUGH 6:00 AM MONDAY

NO EXTENSIONS OF TIME SHALL BE GRANTED FOR DELAYS IN MATERIAL DELIVERIES, UNLESS SUCH DELAYS ARE INDUSTRY WIDE, OR FOR LABOR STRIKES, UNLESS SUCH STRIKES ARE AREA WIDE.

SHOULD THE CONTRACTOR FAIL TO MEET ANY OF THESE REQUIREMENTS, THE CONTRACTOR SHALL BE ASSESSED A DISINCENTIVE IN THE AMOUNT OF \$100 FOR EACH MINUTE THE ABOVE DESCRIBED LANE CLOSURE RESTRICTIONS ARE VIOLATED.

**USE OF STANDARD DRAWINGS:**

FOR THE PURPOSE OF THIS PROJECT, "MOVING OPERATION" SHALL BE LIMITED TO PAVEMENT MARKING STRIPING. IT MAY BE NECESSARY TO EXTEND THE ADVANCE WARNING AND BUFFER ZONES BEYOND THE MINIMUM DISTANCES SHOWN ON THE STANDARD DRAWINGS. THIS MAY BE DUE TO HORIZONTAL ALIGNMENT, VERTICAL ALIGNMENT, RAMP LOCATIONS, OR OTHER SIGHT OBSTRUCTIONS. LOCATIONS OF THE TAPER ZONES MAY BE ADJUSTED AS DIRECTED BY THE ENGINEER, BUT TAPER LENGTHS MUST MEET THE MINIMUM STANDARDS. TAPERS SHOULD BE PLACED IN TANGENT SECTIONS WHENEVER POSSIBLE. ADDITIONAL YIELD SIGNS MAY BE REQUIRED FOR RAMPS WITHIN 1,000 FEET OF A WORK ZONE. PAYMENT SHALL BE INCLUDED IN THE LUMP SUM CONTRACT PRICE FOR ITEM 614 MAINTAINING TRAFFIC.

**TRUCK MOUNTED ATTENUATOR (TMA) - TWO LANE ROADS**

WHEN WORKING IN A CLOSED LANE OR SHOULDER ON A TWO LANE HIGHWAY WITHOUT TEMPORARY OR PERMANENT TRAFFIC BARRIERS SEPARATING THE WORK AREA FROM THE TRAVELED LANE, A TRUCK MOUNTED ATTENUATOR (TMA) SHALL BE PROVIDED TO PROTECT EACH WORK AREA IN ACCORDANCE WITH ODOT TYPICAL APPLICATION (TA) 4, TA-6 AND TA-17, ALONG WITH STANDARD CONSTRUCTION DRAWING (SCD) MT-97.10. THE TMA SHALL BE PLACED IN SUCH A WAY TO ADEQUATELY PROTECT THE WORKERS INSIDE THE WORK ZONE. THE TMA IS NOT INTENDED TO BE USED AS OR SUBSTITUTED FOR THE FLAGGERS AND/OR WARNING SIGNS AND DEVICES. THE TMA SHALL MEET NCHRP 350 TEST LEVEL 3 CRITERIA FOR STANDARD AND OPTIONAL TESTS AT 100 KM/H (62 MPH) FOR DESIGN IMPACTS. THE COST FOR PROVIDING THE TMA SHALL INCLUDE ALL MATERIAL, LABOR, EQUIPMENT, AND HARDWARE REPLACEMENT AND IS TO BE INCLUDED IN THE LUMP SUM BID PRICE FOR ITEM 614 - MAINTAINING TRAFFIC.

**ITEM 614 - PORTABLE CHANGEABLE MESSAGE SIGN, AS PER PLAN:**

THE CONTRACTOR SHALL FURNISH, INSTALL, MAINTAIN, AND REMOVE WHEN NO LONGER NEEDED, CHANGEABLE MESSAGE SIGNS, ON SITE, TO BE USED AS DIRECTED.

THE SIGN SHALL BE OF A TYPE SHOWN ON A LIST OF APPROVED PCMS UNITS MAINTAINED BY THE DIRECTOR. ONLY CLASS I OR II SIGNS WILL BE PERMITTED. EACH SIGN SHALL BE TRAILER MOUNTED AND EQUIPPED WITH A FUNCTIONAL DIMMING MECHANISM TO DIM THE SIGN DURING DARKNESS AND A TEMPER AND VANDAL PROOF ENCLOSURE. EACH SIGN SHALL BE PROVIDED WITH APPROPRIATE TRAINING AND OPERATION INSTRUCTIONS TO ENABLE ON-SITE PERSONNEL TO OPERATE AND TROUBLE SHOOT THE UNIT. THE SIGN SHALL ALSO BE CAPABLE OF BEING POWERED BY AN ELECTRICAL SERVICE DROP FROM A LOCAL UTILITY COMPANY. PLACEMENT OF THE PCMS'S SHALL BE AS DIRECTED BY THE ENGINEER.

SIGN ACTIVATION SHALL BE 7 DAYS PRIOR TO CONSTRUCTION INITIATION OR AS DIRECTED BY THE ENGINEER. OPERATION AND MAINTENANCE OF THE SIGNS BY THE CONTRACTOR SHALL BE AS DIRECTED BY THE ENGINEER. THE PCMS SHALL BE LOCATED IN A HIGHLY VISIBLE POSITION YET PROTECTED FROM TRAFFIC. THE CONTRACTOR SHALL, AT THE DIRECTION OF THE ENGINEER, RELOCATE THE PCMS TO IMPROVE VISIBILITY OR ACCOMMODATE CHANGED CONDITIONS. WHEN NOT IN USE, THE PCMS WILL BE OFF, FACING AWAY FROM ALL TRAFFIC, AND SHALL DISPLAY ONE OR MORE HIGH INTENSITY YELLOW REFLECTIVE SHEETING SURFACES OF 9 INCHES BY 15 INCHES MINIMUM, FACING TRAFFIC.

**USE OF WEIGHTED CHANNELIZER:**

THE WEIGHTED CHANNELIZER MAY BE USED IN ACCORDANCE WITH THIS SECTION. THE WEIGHTED CHANNELIZER SHALL BE PREDOMINANTLY ORANGE IN COLOR AND SHALL BE MADE OF LIGHTWEIGHT, FLEXIBLE, AND DEFORMABLE MATERIAL. THEY SHALL BE AT LEAST 42 INCHES IN HEIGHT WITH A WEIGHTED BASE. THEY MAY HAVE A HANDLE OR LIFTING DEVICE WHICH EXTENDS ABOVE THE 42" MINIMUM HEIGHT.

THE MARKINGS ON THE WEIGHTED CHANNELIZER SHALL BE HORIZONTAL, CIRCUMFERENTIAL, ALTERNATING ORANGE AND WHITE RETROREFLECTIVE STRIPES 6 INCHES WIDE. EACH WEIGHTED CHANNELIZER SHALL HAVE

A MINIMUM OF TWO ORANGE AND TWO WHITE STRIPES. ANY NON-RETROREFLECTIVE SPACES BETWEEN THE HORIZONTAL ORANGE AND WHITE STRIPES SHALL NOT EXCEED 2 INCHES WIDE. THE WEIGHTED CHANNELIZER SHALL HAVE A 4-INCH MINIMUM WIDTH, REGARDLESS OF ORIENTATION.

USE OF WEIGHTED CHANNELIZERS ON FREEWAYS AND MULTILANE HIGHWAYS SHALL BE LIMITED TO SHORT-TERM OPERATION FOR EITHER DAY OR NIGHT. UPON COMPLETION OF WORK, THE WEIGHTED CHANNELIZERS SHALL BE REMOVED. THE WEIGHTED CHANNELIZERS MAY AGAIN BE PLACED ON THE HIGHWAY WHEN THE WORK IS TO RESUME ON THE FOLLOWING DAY OR NIGHT. ANY LANE CLOSURE USING CHANNELIZATION DEVICES, EXPECTED TO REMAIN FOR MORE THAN TWELVE HOURS, SHALL REQUIRE THE USE OF DRUMS OR BARRIERS.

WHEN USED AT NIGHT, WEIGHTED CHANNELIZERS SHALL ONLY BE PLACED IN THE TANGENT AREA. THE TANGENT AREA IS DEFINED AS THE AREA AFTER THE TRANSITION TAPER WHERE THE WORK TAKES PLACE. DRUMS SHALL BE USED IN THE TRANSITION TAPERS FOR NIGHT OPERATIONS. MAXIMUM SPACING OF THE WEIGHTED CHANNELIZER SHALL BE 40 FEET AT NIGHT.

STEPS SHOULD BE TAKEN TO ENSURE THAT THE WEIGHTED CHANNELIZERS WILL NOT BE BLOWN OVER OR DISPLACED BY WIND OR MOVING TRAFFIC. BALLASTS SHOULD NOT PRESENT A HAZARD IF THE WEIGHTED CHANNELIZERS ARE INADVERTENTLY STRUCK, NOR SHOULD THEY AFFECT THE VISIBILITY OF THE WEIGHTED CHANNELIZERS. ALL BALLASTS USED SHOULD BE IN ACCORDANCE WITH THE MANUFACTURER'S SPECIFICATIONS.

I:\ProjectData\07824\_PIC-316-13.05\Design\Roadway\Sheets\GN\_001.dgn MN\_0012/16/2019 2:49:30 PM rmcneill

CALCULATED  
RAM  
CHECKED  
XXX

MAINTENANCE OF TRAFFIC NOTES

PIC-SR 316 / 752 -  
13.05 / 0.00

**NOTIFICATION OF CONSTRUCTION INITIATION:**

AT LEAST FOURTEEN DAYS PRIOR TO ANY CONSTRUCTION ACTIVITIES, THE CONTRACTOR SHALL ADVISE THE DISTRICT OFFICE OF COMMUNICATIONS VIA EMAIL AT [d06.pio@dot.ohio.gov](mailto:d06.pio@dot.ohio.gov) AND THE DISTRICT WORK ZONE TRAFFIC MANAGER VIA EMAIL AT [d06.mot@dot.ohio.gov](mailto:d06.mot@dot.ohio.gov) OF THE ANTICIPATED START DATE OF ANY CONSTRUCTION ACTIVITIES, INCLUDING BUT NOT LIMITED TO THE PLACING OF WORK ZONE SIGNS. THE NOTIFICATION SHALL ALSO INCLUDE THE PROJECT NUMBER, PID, NAME AND NUMBER OF THE CONTRACTOR, A POINT OF CONTACT AND THE ANTICIPATED IMPACT ON TRAFFIC. THE CONTRACTOR WILL IMMEDIATELY INFORM THE DISTRICT OFFICE OF COMMUNICATIONS AND THE DISTRICT WORK ZONE TRAFFIC MANAGER OF ANY DELAYS AND/OR CHANGES REGARDING THE CONSTRUCTION INITIATION DATE.

**PUBLIC OUTREACH AND NOTIFICATION:**

THE CONTRACTOR SHALL BE RESPONSIBLE FOR CONTACTING THE DISTRICT 6 PUBLIC INFORMATION OFFICE VIA EMAIL AT [d06.pio@dot.ohio.gov](mailto:d06.pio@dot.ohio.gov) TO COORDINATE EFFORTS TO NOTIFY ADJACENT RESIDENTS AND BUSINESSES OF THE UPCOMING RESURFACING PROJECT. ADVANCE NOTIFICATION SHALL OCCUR NO LATER THAN FOURTEEN (14) DAYS PRIOR TO THE FIRST DAY OF WORK (EACH LOCATION). ALL NOTIFICATIONS SHALL BE MADE UTILIZING THE TEMPLATE PROVIDED BY THE DISTRICT 6 PUBLIC INFORMATION OFFICE.

**PERMITTED LANE CLOSURES:**

AT LEAST ONE LANE OF TWO-WAY TRAFFIC SHALL BE MAINTAINED AT ALL TIMES BY USE OF THE EXISTING AND COMPLETED PAVEMENT. WORK ZONES SHALL BE LIMITED IN LENGTH TO THE AMOUNT OF WORK THAT CAN BE PERFORMED THAT DAY. TRAFFIC SHALL BE MAINTAINED BY FLAGGERS FOR CLOSING 1 LANE OF THE 2 LANE HIGHWAY FOR PAVING OPERATION AS PER STANDARD DRAWING MT-97.12.

LENGTH AND DURATION OF LANE CLOSURES AND RESTRICTIONS SHALL BE AT THE APPROVAL OF THE ENGINEER. IT IS THE INTENT TO MINIMIZE THE IMPACT TO THE TRAVELING PUBLIC. LANE CLOSURES OR RESTRICTIONS OVER SEGMENTS OF THE PROJECT IN WHICH NO WORK IS ANTICIPATED WITHIN A REASONABLE TIME FRAME, AS DETERMINED BY THE ENGINEER, SHALL NOT BE PERMITTED. THE LEVEL OF UTILIZATION OF MAINTENANCE OF TRAFFIC DEVICES SHALL BE COMMENSURATE WITH THE WORK IN PROGRESS.

ALL WORK AND TRAFFIC CONTROL DEVICES SHALL BE IN ACCORDANCE WITH CMS 614 AND OTHER APPLICABLE PORTIONS OF THE SPECIFICATIONS, AS WELL AS THE OHIO MANUAL OF UNIFORM TRAFFIC CONTROL DEVICES. PAYMENT FOR ALL LABOR, EQUIPMENT AND MATERIALS SHALL BE INCLUDED IN THE LUMP SUM CONTRACT PRICE FOR ITEM 614, MAINTAINING TRAFFIC, UNLESS SEPARATELY ITEMIZED IN THE PLAN.

SHOULD THE CONTRACTOR FAIL TO MEET ANY OF THESE REQUIREMENTS, THE CONTRACTOR SHALL BE ASSESSED A DISINCENTIVE IN THE AMOUNT OF \$100 FOR EACH MINUTE THE ABOVE DESCRIBED LANE CLOSURE RESTRICTIONS ARE VIOLATED.

**NOTIFICATION OF TRAFFIC RESTRICTIONS**

THROUGHOUT THE DURATION OF THE PROJECT, THE CONTRACTOR SHALL NOTIFY THE PROJECT ENGINEER IN WRITING OF ALL TRAFFIC RESTRICTIONS AND UPCOMING MAINTENANCE OF TRAFFIC CHANGES. THE CONTRACTOR SHALL ENSURE THE WRITTEN NOTIFICATION IS SUBMITTED IN A TIMELY MANNER TO ALLOW THE PROJECT ENGINEER TO MEET THE REQUIRED TIME FRAMES SET FORTH IN THE TABLE BELOW TO INFORM SPECIAL HAULING PERMITS SECTION (HAULING.PERMITS@DOT.OHIO.GOV) AND THE DISTRICT PUBLIC INFORMATION OFFICE (PIO). THIS NOTIFICATION SHALL BE RECEIVED BY THE PROJECT ENGINEER PRIOR TO THE PHYSICAL SETUP OF ANY APPLICABLE SIGNS OR MESSAGE BOARDS.

INFORMATION SHOULD INCLUDE BUT IS NOT LIMITED TO ALL CONSTRUCTION ACTIVITIES THAT IMPACT OR INTERFERE WITH TRAFFIC AND SHALL LIST THE SPECIFIC LOCATION, TYPE OF WORK, ROAD STATUS, DATE AND TIME OF RESTRICTION, DURATION OF RESTRICTION, NUMBER OF LANES MAINTAINED, NUMBER OF LANES CLOSED, MINIMUM VERTICAL CLEARANCE, MINIMUM WIDTH OF DRIVABLE PAVEMENT, DETOUR ROUTES IF APPLICABLE, AND ANY OTHER INFORMATION REQUESTED BY THE PROJECT ENGINEER.

**Notification Time Frame Table**

Item	Duration of Closure	Notification due to District 6 Communications Office	Sign Displayed to Public
Ramp & Road Closures	>= 2 weeks	21 calendar days prior to closure	14 calendar days prior to closure
	> 12 hours & < 2 weeks	14 calendar days prior to closure	7 calendar days prior to closure
	< 12 hours	4 business days prior to closure	2 business days prior to closure
Lane Closures & Restrictions	>= 2 weeks	14 calendar days prior to closure	
	< 2 weeks	5 business days prior to closure	
Start of Construction & Traffic Pattern Changes	N/A	14 calendar days prior to implementation	

ANY UNFORESEEN CONDITIONS NOT SPECIFIED IN THE PLANS REQUIRING TRAFFIC RESTRICTIONS SHALL ALSO BE REPORTED TO THE PROJECT ENGINEER USING THE NOTIFICATION TIME FRAME TABLE.

**ACCESS TO PRIVATE PROPERTY:**

MAINTAIN ACCESS TO COMMERCIAL PROPERTIES WITH ONLY ONE DRIVEWAY AT ALL TIMES BY USE OF PART WIDTH CONSTRUCTION. FOR COMMERCIAL PROPERTIES WITH MULTIPLE DRIVEWAYS, DO NOT CLOSE MORE THAN ONE DRIVEWAY AT A TIME.

MAINTAIN ACCESS TO RESIDENTIAL PROPERTIES AT ALL TIMES. WHEN A RESIDENTIAL DRIVE IS CLOSED FOR CONSTRUCTION, MAINTAIN ALTERNATE ACCESS TO THE PROPERTY. IT MAY BE REQUIRED FOR THE CONTRACTOR TO MAINTAIN ONE PASSABLE LANE WITHIN A CLOSURE IN ORDER FOR VEHICLES TO ACCESS RESIDENCY WITH A VEHICLE.

**ITEM 614 - WORK ZONE MARKING SIGN, AS PER PLAN:**

"DO NOT PASS" AND "PASS WITH CARE" SIGNS SHALL BE PLACED TO REFLECT THE EXISTING PASSING AND NO PASSING ZONES. THESE SIGNS SHALL BE COVERED OR REMOVED WITHIN 24 HOURS OF THE CORRECTED CENTERLINE MARKINGS AT LOCATIONS SHOWN ON PLAN SHEET 28/36-32/36.

LOC	ROUTE	R4-1-18	R4-2-18	W8-H12A-36
		NO EDGE LINES EACH	DO NOT PASS EACH	PASS WITH CARE EACH
1	PIC-752	14	24	22
SUBTOTAL		14	24	22

THE FOLLOWING QUANTITY HAS BEEN PROVIDED AND THE TOTAL HAS BEEN CARRIED TO THE GENERAL SUMMARY.  
ITEM 614 - WORK ZONE MARKING SIGN, AS PER PLAN =60 EACH

**ITEM 614 - WORK ZONE CENTER LINE, CLASS III, 642 PAINT:**

WORK ZONE CENTER LINE SHALL BE PLACED TO REFLECT THE PROPOSED CENTER LINE AS DETERMINED FROM THE PROPOSED MARKINGS WITHIN THE PROJECT LIMITS. IT SHALL BE THE CONTRACTOR'S RESPONSIBILITY TO VERIFY THE LOCATION, SIZE, AND TYPE OF WORK ZONE MARKINGS NEEDED MEETING THE REQUIREMENTS OF ITEM 614 BEFORE THE REMOVAL OR RESURFACING OBLITERATES THE EXISTING.

LOC	ROUTE	BEGIN	END	QUANTITY	UNIT
1	PIC-752	0.00	1.74	1.74	MI
1	PIC-752	1.92	8.43	6.51	MI
				8.25	MI

THE FOLLOWING QUANTITY HAS BEEN PROVIDED AND THE TOTAL HAS BEEN CARRIED TO THE GENERAL SUMMARY.  
ITEM 614 - WORK ZONE CENTER LINE, CLASS III, 642 PAINT = 8.25 MILE X 2 = 16.50 MILE TOTAL

**ITEM 614 - WORK ZONE STOP LINE, CLASS III, 642 PAINT:**

WORK ZONE STOP LINE SHALL BE PLACED TO REFLECT THE EXISTING STOP LINE AS DETERMINED FROM THE EXISTING MARKINGS WITHIN THE PROJECT LIMITS. IT SHALL BE THE CONTRACTOR'S RESPONSIBILITY TO VERIFY THE LOCATION, SIZE, AND TYPE OF WORK ZONE MARKINGS NEEDED MEETING THE REQUIREMENTS OF ITEM 614 BEFORE THE REMOVAL OR RESURFACING OBLITERATES THE EXISTING.

THE FOLLOWING QUANTITY HAS BEEN PROVIDED AND THE TOTAL HAS BEEN CARRIED TO THE GENERAL SUMMARY.

LOCATION 1 PIC-752-0.00 TO 8.43

- SLM 0.00 - 14 FT
- 1.56 - 11 FT
- 1.58 - 11 FT
- 2.31 - 11 FT
- 2.34 - 11 FT
- 5.14 - 11 FT
- 5.22 - 11 FT
- 6.27 - 11 FT
- 6.30 - 11 FT
- 8.43 - 11 FT

SUBTOTAL = 113 FT X 2 = 226 FT TOTAL

